

Water Supply Network Approved Materials List

June 2023

Introduction

The water supply network approved materials list covers all materials for projects on Christchurch City Council (Council) owned water supply infrastructure or water supply infrastructure to be vested in Council. The approved materials list both states the manufacturing standard, size and performance requirements for all commonly used water supply product types and lists specific products meeting the manufacturing, performance and quality assurance requirements.

Selection of materials and products for installation in a specific location shall consider the particular, site-specific design constraints in conjunction with Council's Infrastructure Design Standards (IDS), Construction Standard Specification (CSS) and approved materials list.

Where installation of materials or products not holding approval occurs, Council retains the right to require replacement with approved products at the cost of the designer, contractor or developer responsible.

Applying For and Maintaining Approval

Applying for Approval

Send applications for material approval to approvedmaterials@ccc.govt.nz

Each application for material approval must:

1. State the network or networks where the material is suitable for use
2. State the product type for each product. Product types should be those listed on the approved materials list
3. List the brand name, manufacturer and suppliers for each product
4. Include a third party certificate, complete with accompanying schedule, showing the product complies with the manufacturing standard for the product type as listed on the approved materials list.
5. Include a third party certificate showing the manufacturers quality assurance system complies with ISO 9001.

Material approvals expire on the earliest certification expiry date, that is whichever is earlier of the expiry dates of the manufacturing standard certification or the ISO 9001 certification. Where a certificate is open ended and has no expiry date, we will assume a one-year timeframe for that certificate.

The approved materials committee aims to meet monthly for discussion and consideration of new applications. Approval of applications for existing product types, where the application includes all required information, typically occurs within one to five weeks dependent on when we receive the application relative to the meeting. Where we need more information or approval requires creation of a new product type, longer timeframes will be involved.

Updating Expired Approvals

Approval expires due to certifications becoming out of date. To re-activate the approval and extend the expiry date, send new manufacturing certificates (including schedules) and/or ISO 9001 certificates to approvedmaterials@ccc.govt.nz

Updates do not require a committee meeting and therefore have shorter periods. Publishing and upload to the Council website of the updated approved materials list occurs eleven times a year on the last day of every month except December. For inclusion in the updated approved materials list new certificates must arrive a minimum of three working days before the end of the month.

Preferably updates should occur before approval expiry. On reaching 3 months past approval expiry, update is no longer possible and approval will require a new application.

Definitions

Approval Type Definitions

The approved materials list contains only those products that hold approval or restricted approval for use in Council networks or networks that will be vested in Council. For all approval types the approval applies only for the stated sizes/diameters, pressure ratings, materials and coatings. The following sub-sections list the approval types and conditions applying to each approval type.

Products listed below approved for use as permitted by IDS and CSS

Products with this approval type hold approval Where a product type has this approval type the specific models and brands listed may be installed where their use is in compliance with Council Infrastructure Design Standards (IDS) and Construction Standard Specifications (CSS).

This approval size only applies up to and including a diameter of 600mm. Sizes larger than 600mm nominal diameter require project specific approval as per section 2.1.2.

Project specific approval required to use products listed below

Use of products with this approval type requires approval from the Council project manager or subdivision engineer. Prior to issuing approval the Council project manager or subdivision engineer may require evidence showing that the proposed product type provides benefits over product types holding approval for general use as per 2.1.1. Use of these products shall comply with the IDS and CSS.

Where a product holds general approval as per 2.1.1 but the project requires sizes greater than 600mm nominal bore, Council project managers or subdivision engineers will assess the proposed size meets future network requirements and is consistent with sizes already in use.

Products listed below approved for use as specials only

Use of products approved for use as specials only is limited to short sections as required to avoid service clashes, avoid hazards, or required to be fabricated on-site. Use of these products shall comply with the IDS and CSS.

Products listed below approved for use during repairs only

Some products preferred for use when installing new infrastructure are not able to be used when conducting maintenance on the network due to the conditions in the trench. Products listed as for use during repairs only provide an alternative solution to permit completion of works.

Use of products approved for use during repairs only shall occur only when conducting planned or reactive works on the existing network. These products shall not be used during the installation of new infrastructure.

For all approval types only the listed makes and models are approved, and only up until the expiry date shown.

Product Type Definitions

A separate page lists approved makes and models for each product type. Terminology referring to the individual product types can be confusing, to remove confusion we give the following definitions of commonly used terms:

Adaptor

A straight-through fitting with different connection types at each end. Reducers and bends can also act as adaptors but are listed as a reducer or bend. Threaded fittings and fittings incorporating mechanical joints are listed separately.

Bend

Any fitting incorporating a directional change.

Branch Saddle

Electrofusion fitting that requires later tapping of the branch connection, using a separate tool.

Coupler

Straight-through fitting with no diameter change for connecting similar diameter pipes.

Diamètre Nominal/Durchmesser Nach Norm (DN)

Typically used in the designation of PE pipes or fittings, DN is used to indicate the nominal external diameter of pipe.

Double Check Valve Backflow Preventer

Backflow preventor for medium hazard protection. A double check valve Backflow Preventer incorporates two check valves in series and incorporates ports for testing.

Dual Check Device Backflow Preventer

Backflow preventor for low hazard protection. A dual check device backflow preventer incorporates two check valves in series but is not testable.

Gate Valve

Valve that closes by dropping a plate or wedge into the flow. A gate valve has a slot in the invert that the plate or wedge drops into.

Nominal Bore (NB)

NB is used to indicate the nominal or rounded internal diameter of the pipe.

Reduced Pressure Zone (RPZ)

Backflow preventor for high hazard protection. A RPZ incorporates two check valves separated by a pressure monitored chamber capable of venting excess pressure. RPZs incorporate test ports.

Reducer

Tapered or stepped fitting to change the pipe diameter.

Sluice Valve

Valve that closes by dropping a plate or wedge into the flow. A sluice valve has a continuous invert and the plate or wedge matches the shape of and seals against the invert.

Stop Cock

A ball valve specifically for the individual customer connection on each lateral.

Tapping Band

A ring clamped around a pipe allowing the connection of a branch pipe or fitting.

Tapping Saddle

Electrofusion fitting that incorporates a mechanism for tapping the branch connection.

Threaded Transition

Adaptor with a British Standard Pipe (BSP) thread at one end and an alternative connection type at the other. Threaded transitions may be straight-through or incorporate a change in direction.

Contents

Introduction	i
Applying for and Maintaining Approval	ii
Definitions	iii
Section 1: Pipes	2
Section 2: Valves and Hydrants	10
Section 3: Mechanical Couplers and Adaptors	25
Section 4: DI Fittings	30
Section 5: Electrofusion Fittings	39
Section 6: Butt-Weld Fusion Fittings	47
Section 7: Compression Fittings	53
Section 8: Junctions and Take-Off Fittings	62
Section 9: Surface Boxes	71
Section 10: Miscellaneous	78
Appendix 1: PE Manufacturers Action Memo	84
Appendix 2: PVC Witness Mark Memo	86
Appendix 3: Stub Flange and Backing Ring Table	89

Section 1

Pipes

Pipe Type	Page
Unplasticised Polyvinyl Chloride (U-PVC) Series 1 Pipe	3
Polyethylene (PE) Pipe	4
Polyethylene (PE) and Aluminium Barrier Pipe	5
Ductile Iron (DI) Pipe	6
Cement Lined Steel (CLS) Pipe	7
Glass Reinforced Plastic (GRP) Pipe	8
Schedule 40 Steel Pipe	9

Approved Materials List

Network: Water Supply (pressure)
Product Type: Pipe
Material: PVC-U Series 1

Approval Type: Products listed below approved for use as permitted by IDS and CSS

Performance Requirements

Manufacturing Standard: AS/NZS 1477
Material Specification: Unplasticized Polyvinylchloride (PVC-U)

Coating Specification: Not applicable.
Pressure Ratings: PN12 or PN15
Approved Sizes: 100NB, 150NB, 200NB, 300NB, 375NB, 450NB, 575NB.
Operational Life: 100 Years
Other Requirements:

- Product shall be certified to AS/NZS 4020 or DWI (UK).
- End caps to be retained on pipe until installation.
- Colour shall be white.
- Refer to Appendix 2 - PVC Witness Mark memo.

Brand Name	Manufacturer	Supplier	Approval Expires
Novakey	Iplex Pipelines NZ Ltd	Hynds, Humes	3/02/2024
Powerlock 800 RJ	RX Plastics Ltd	Marley	18/03/2024

Approved Materials List

Network: Water Supply (pressure)
Product Type: Pipe
Material: Polyethylene (PE)

Approval Type: Products listed below approved for use as permitted by IDS and CSS

Performance Requirements

Manufacturing Standard: AS/NZS 4130
Material Specification: PE80b or PE100 Polyethylene to AS/NZS 4131.

Coating Specification: Not applicable.

Pressure Ratings: PE80b shall be PN12.5 SDR11 or PN16 SDR9
 PE100 shall be PN12.5 SDR13.6 or PN16 SDR11

Approved Sizes: PE80b shall be DN20, EN25, DN32, DN50, and DN63
 PE100 shall be DN110, DN125, DN180, DN250, DN355, DN450, DN560 or DN710

Operational Life: 100 Years

Other Requirements:

- Product shall be certified to AS/NZS 4020 or DWI (UK).
- DN110 shall only be used for hydrant risers.
- End caps to be retained on pipe until installation.
- Colours: PE80b - Blue jacket or minimum 4 stripes no darker than RAL 5012. PE100 - Blue jacket or minimum 4 stripes no lighter than RAL 5005.
- Refer to Appendix 1 - PE Manufacturers Actions memo.

Brand Name	Manufacturer	Supplier	Approval Expires
Blue Jacket	Asmuss Ltd	Asmuss Ltd	24/05/2019
Blue Stripe	Asmuss Ltd	Asmuss Ltd	24/05/2019
Blueline	Iplex Pipelines NZ Ltd	Humes, Hynds	3/02/2024
Blackline	Iplex Pipelines NZ Ltd	Humes, Hynds	3/02/2024
1200 Series PE80	RX Plastics Ltd	Marley	18/03/2024
1210 Series PE100	RX Plastics Ltd	Marley	18/03/2024
Polyethylene Pipe	Steel and Tube Plastics Ltd	Steel and Tube Ltd	4/10/2018
TUBI HDPE	Tubi Operations Pty Ltd	Tubi Group Pty Ltd	28/02/2018
Series 1	Waters & Farr Ltd	Hynds	24/08/2023
EnviroPressure Pipe	Enviropipes Pty Ltd	Enviropipes Pty Ltd	21/02/2024

Approved Materials List

Network: Water Supply (pressure)
Product Type: Pipe
Material: PE Barrier Pipe (PE-Al-PE)

Approval Type: Products listed below approved for use as permitted by IDS and CSS

Performance Requirements

Manufacturing Standard: BS 8588
Material Specification: PE80b with Aluminium Foil Layer

Coating Specification: N/A
Pressure Ratings: PN12.5 or PN16
Approved Sizes: DN25, DN32 and DN63
Operational Life: 100 years
Other Requirements:

- Product shall be certified to AS/NZS 4020 or DWI (UK).
- End caps to be retained on pipe until installation.
- Pipe manufacturers to specify compatible fittings as part of application process. Fittings shall maintain a contamination barrier without the need for wrapping the fitting.
- Pipe shall be blue no lighter than RAL 5005 and no darker than RAL 5012. Pipe shall have minimum of 4 longitudinal brown stripes located equidistantly around the circumference.
- Refer to Appendix 1 - PE Manufacturers Actions memo.

Brand Name	Manufacturer	Supplier	Approval Expires
Puriton Pipe and Fittings	Radius Systems Ltd	Hynds	12/04/2024

Approved Materials List

Network: Water Supply (pressure)
Product Type: Pipe
Material: Ductile Iron (DI) / Mortar Lined Ductile Iron (MLDI)

Approval Type: Products listed below approved for use as permitted by IDS and CSS

Performance Requirements

Manufacturing Standard: AS/NZS 2280
Material Specification: Ductile Iron to AS/NZS 2280

Coating Specification: Internal cement mortar lining.
 External bitumen or synthetic base coating

Pressure Ratings: PN35

Approved Sizes: 100NB, 150NB, 200NB, 300NB, 375NB, 450NB and 600NB

Operational Life: 130 years

Other Requirements:

- Product shall be certified to AS/NZS 4020 or DWI (UK).
- End caps to be retained on pipe until installation.
- End restraint joints only where required by specific design or where indicated for pipe laying on sloping ground.
- Pipe shall have a Blue PE sleeve in accordance with AS3680. Sleeve shall be carefully applied and repaired when damaged.
- Seal coating may be required over cement mortar linings, when conveying soft water or in low flow extremities of reticulation network.

Brand Name	Manufacturer	Supplier	Approval Expires
Hydrotite	Gillies Metaltech	Hynds	17/07/2023
Classic	PAM Saint-Gobain (Maanshan)	P & I	14/11/2023
TytonExcel	PAM Saint-Gobain (Xuzhou)	Asmuss	15/09/2018
TytonExtreme	PAM Saint-Gobain (Xuzhou)	Asmuss	15/09/2018
TytonXcel	Xinxing DI Pipes Co Ltd	Viadux Pty Ltd	31/07/2024
TytonXcel Z+	Xinxing DI Pipes Co Ltd	Viadux Pty Ltd	31/07/2024
TytonXceed Z+	Xinxing DI Pipes Co Ltd	Viadux Pty Ltd	31/07/2024

Approved Materials List

Network: Water Supply (pressure)
Product Type: Pipe
Material: Cement Mortar Lined Steel (CLS)

Approval Type: Products listed below approved for use as specials only

Performance Requirements

Manufacturing Standard: NZS 4442 and AS 1579, Protection to AS/NZS 2312

Material Specification: Carbon steel

Coating Specification: Internal cement mortar lining. Exterior enamel or HDPE coating.

Pressure Ratings: PN16, PN20 or PN35

Approved Sizes: 100NB, 150NB, 200NB, 300NB, 450NB and 600NB

Operational Life: 80 Years

- Other Requirements:**
- Product shall be certified to AS/NZS 4020 or DWI (UK).
 - End caps to be retained on pipe until installation.
 - Pipe shall have a Blue PE sleeve in accordance with AS3680. Sleeve shall be carefully applied and repaired when damaged.
 - Seal coating may be required over cement mortar linings, when conveying soft water or in low flow extremities of reticulation network.
 - 6m lengths with outer diameters of 114 (100NB), 168 (150NB), 219 (200NB), 324 (300NB), 457 (450NB) or 610 (600NB).

Brand Name	Manufacturer	Supplier	Approval Expires

Approved Materials List

Network: Water Supply (pressure)
Product Type: Pipe
Material: Glass Reinforced Plastic (GRP)

Approval Type: Project specific approval required to use products listed below

Performance Requirements

Manufacturing Standard: AS 3571.2
Material Specification: Glass reinforced plastic to AS 3571.2

Coating Specification: N/A
Pressure Ratings: PN12 or PN15
Approved Sizes: 300NB, 375NB, 450NB and 600NB
Operational Life: 100 years
Other Requirements:

- Product shall be certified to AS/NZS 4020 or DWI (UK).
- End caps to be retained on pipe until installation.

Brand Name	Manufacturer	Supplier	Approval Expires

Approved Materials List

Network: Water Supply (pressure)
Product Type: Pipe
Material: Schedule 40 Steel

Approval Type: Project specific approval required to use products listed below

Performance Requirements

Manufacturing Standard: API Specification 5L
Material Specification: Carbon Steel

Coating Specification: Galvanised to AS/NZS 4680

Pressure Ratings: PN16, PN20 or PN35

Approved Sizes: 100NB, 150NB, 200NB, 300NB, 375NB, 450NB AND 600NB

Operational Life: 130 years

Other Requirements:

- Product shall be certified to AS/NZS 4020 or DWI (UK).
- End caps to be retained on pipe until installation.
- Joints shall be flanged to full requirements of AS/NZS 4087 Figure B5.
- Pipe shall have a Blue PE sleeve in accordance with AS3680. Sleeve shall be carefully applied and repaired when damaged.

Brand Name	Manufacturer	Supplier	Approval Expires

Section 2

Valves and Hydrants

Valve Type	Page
Sluice Valve	11
Gate Valve	12
Fire Hydrant - Tall Pattern	13
Fire Hydrant - Squat Pattern	14
Butterfly Valve	15
Stop Cock	16
Stop Cock with Integral Dual Check Device	17
Dual Check Device Backflow Preventer	18
Double Check Valve Backflow Preventer (>50NB)	19
Double Check Valve Backflow Preventer (≤50NB)	20
Reduced Pressure Zone Backflow Preventer (>50NB)	21
Reduced Pressure Zone Backflow Preventer (≤50NB)	22
Swing-Check Valve	23
Dual Plate Wafer Check Valve	24

Approved Materials List

Network: Water Supply (pressure)
Product Type: Sluice Valve
Material: Ductile Iron (DI)

Approval Type: Products listed below approved for use as permitted by IDS and CSS

Performance Requirements

Manufacturing Standard: AS/NZS 2638.2

Material Specification: Body: Ductile Iron (DI) to AS/NZS2280.
 Seal: EPDM or Nitrile Rubber.

Coating Specification: Thermally bonded polymeric coating to AS/NZS 4158.

Pressure Ratings: PN16

Approved Sizes: 50, 80, 100, 125, 150, 175, 200, 225, 250, 300, 375, 450 and 600 nominal bore.

Operational Life: 100 Years

- Other Requirements:**
- Product shall be certified to AS/NZS 4020 or DWI (UK).
 - End Configurations: Flange-Flange.
 - Flanges shall be fully compliant with AS/NZS 4087 Figure B5.
 - Operation: Clockwise to open.
 - Spindle shall be extendable.
 - Valves shall be supplied with a square spindle cap secured with a set screw.
 - Name plate markings shall provide traceability of the valve.

Brand Name	Manufacturer	Supplier	Approval Expires
AVK Series 570	AVK Australia Pty Ltd.	Humes	14/02/2024
Derwent Resilient Seated Gate	Derwent Industries Pty Ltd.	Derwent Industries Pty Ltd.	#N/A
Sureflow - Fig 500	AVK Australia Pty Ltd.	Asmuss Water Systems Ltd	14/02/2024
Sureflow - Auslite	AVK Australia Pty Ltd.	Asmuss Water Systems Ltd	14/02/2024
Hawle E2	Hawle Armaturenwerke GmbH	Hynds/Hygrade	31/03/2024
Hawle E3	Hawle Armaturenwerke GmbH	Hynds/Hygrade	31/03/2024
DIMax Resilient Seated Gate Valve	WeFlo Valve Co Ltd.	Reece Group	23/12/2024
Flange-Flange Resilient Seat Gate Valve	Dalian Reliable Industrial Co Ltd.	Daemco Australia Pty Ltd	16/01/2026

Approved Materials List

Network: Water Supply (pressure)
Product Type: Gate Valve
Material: Copper Alloy

Approval Type: Products listed below approved for use as permitted by IDS and CSS

Performance Requirements

Manufacturing Standard: AS 1628 or BS/NZS 5154

Material Specification: Body: AS 1565, C83600. 85/5/5/5 Leaded Gunmetal.
 Seals: EPDM or Nitrile Rubber.

Coating Specification: N/A

Pressure Ratings: PN14

Approved Sizes: 15NB, 20NB, 25NB, 32NB, 40NB and 50NB.

Operational Life: 100 years.

- Other Requirements:**
- Product shall be certified to AS/NZS 4020 or DWI (UK).
 - End Configurations: Female BSP thread-Female BSP thread.
 - Operation: Anticlockwise to open.
 - Non-rising stem designs shall be used.
 - Valve stems shall be fitted with a hand wheel.
 - Name plate markings shall provide traceability of the valve.

Brand Name	Manufacturer	Supplier	Approval Expires
Ban Chang	Ban Chang Hardware Co. Ltd	P & I	19/08/2019
Ban Chang (Green Handle)	Ban Chang Hardware Co. Ltd	Humes, Hynds	19/08/2019
Kitz	Kitz (Thailand) Ltd	Steel and Tube Plastics	18/06/2022
Red Handle	Cav Uff Giacomo Cimberio SpA	P & I	12/08/2022

Approved Materials List

Network: Water Supply (pressure)
Product Type: Fire Hydrant - Tall Pattern
Material: Ductile Iron (DI)

Approval Type: Products listed below approved for use as permitted by IDS and CSS

Performance Requirements

Manufacturing Standard: AS/NZS4522

Material Specification: Body: Ductile Iron (DI) to AS/NZS2280.
 Seals: EPDM or Nitrile Rubber.

Coating Specification: Thermally bonded polymeric coating to AS/NZS 4158.

Pressure Ratings: PN16

Approved Sizes: 80mm

Operational Life: 100 years

Other Requirements:

- Product shall be certified to AS/NZS 4020 or DWI (UK).
- Flanges to meet full requirements of AS/NZS 4087 Figure B5.
- Hydrants shall be supplied with a square spindle cap secured with a set screw.

Brand Name	Manufacturer	Supplier	Approval Expires
AVK 29/589-001	AVK Australia Pty Ltd.	Humes	14/02/2024
NZ Fire Hydrant - Tall	Derwent Industries Pty Ltd.	Derwent Industries Pty Ltd.	4/07/2024
Gillies Type A	Gillies Metaltech	Hynds/Hygrade	17/07/2023

Approved Materials List

Network: Water Supply (pressure)
Product Type: Fire Hydrant - Squat Pattern
Material: Ductile Iron (DI)

Approval Type: Project specific approval required to use products listed below

Performance Requirements

Manufacturing Standard: AS/NZS4522
Material Specification: Body: Ductile Iron (DI) to AS/NZS2280.
 Seals: EPDM or Nitrile Rubber.
Coating Specification: Thermally bonded polymeric coating to AS/NZS 4158.
Pressure Ratings: PN16
Approved Sizes: 80mm
Operational Life: 100 years
Other Requirements:

- Product shall be certified to AS/NZS 4020 or DWI (UK).
- Flanges to meet full requirements of AS/NZS 4087 Figure B5.
- Hydrants shall be supplied with a square spindle cap secured with a set screw.

Brand Name	Manufacturer	Supplier	Approval Expires
AVK 29/588-001	AVK Australia Pty Ltd.	Humes	14/02/2024
NZ Fire Hydrant - Squat	Derwent Industries Pty Ltd	Derwent Industries Pty Ltd	4/07/2024
Gillies Type B	Gillies Metaltech	Hynds/Hygrade	17/07/2023

Approved Materials List

Network: Water Supply (pressure)
Product Type: Butterfly Valve
Material: Ductile Iron (DI)

Approval Type: Project specific approval required to use products listed below

Performance Requirements

Manufacturing Standard: AS 4795
Material Specification: Body: Ductile Iron (DI) to AS/NZS 2280. Disc and Stem: 316 Stainless Steel.
 Seals: Elastomeric to AS 1646.
Coating Specification: Thermally bonded polymeric coating to AS/NZS 4158.
Pressure Ratings: PN16
Approved Sizes: 400NB, 450NB, 500NB and 600NB.
Operational Life: 100 years
Other Requirements:

- Product shall be certified to AS/NZS 4020 or DWI (UK).
- End Configuration: Flange-Flange.
- Flanges to meet full requirements of AS/NZS 4087 Figure B5.
- Opening Direction: Clockwise
- Spindle: Valves shall be supplied with a square spindle cap secured with set screw and extendable where necessary.
- Name plate markings shall provide traceability of valve.

Brand Name	Manufacturer	Supplier	Approval Expires
AVK 813/82	AVK Australia Pty Ltd.	Humes	14/02/2024
Ozkan Seal on Disc Butterfly Valve	Ozkan Makina	Hygrade	24/10/2024

Approved Materials List

Network: Water Supply (pressure)
Product Type: Stop Cock
Material: Copper alloy

Approval Type: Products listed below approved for use as permitted by IDS and CSS

Performance Requirements

Manufacturing Standard: AS 4796
Material Specification: Body: AS 1565, C83600. 85/5/5/5 Leaded Gunmetal.
 Ball: 316 Stainless Steel. Seals: EPDM or Nitrile Rubber.

Coating Specification: N/A

Pressure Ratings: PN16

Approved Sizes: 15NB, 20NB, 25NB, 32NB and 40NB.

Operational Life: 100 years.

- Other Requirements:**
- Product shall be certified to AS/NZS 4020 or DWI (UK).
 - End Configurations: Female BSP thread-Female BSP thread.
 - Configuration: Body designs shall be straight through or 90 degree.
 - 15mm stopcock shall be a 20mm nominal bore valve fitted with a 15mm outlet.
 - Internal diameters of ball or other parts shall not have a smaller diameter than the outlet.

Brand Name	Manufacturer	Supplier	Approval Expires
Water Meter Ball Valve	Strongcast Pty Ltd	Strongcast Pty Ltd	9/04/2025

Approved Materials List

Network: Water Supply (pressure)
Product Type: Stopcock with Integral Dual Check Device
Material: Copper Alloy

Approval Type: Products listed below approved for use as permitted by IDS and CSS

Performance Requirements

Manufacturing Standard: AS/NZS 4796 and AS/NZS 2845.
Material Specification: Body: AS 1565, C83600. 85/5/5/5 Leaded Gunmetal.
 Ball: 316 Stainless Steel. Seals: EPDM or Nitrile Rubber.
Coating Specification: N/A
Pressure Ratings: PN16
Approved Sizes: 15NB, 20NB and 25NB.
Operational Life: 100 years.
Other Requirements:

- Product shall be certified to AS/NZS 4020 or DWI (UK).
- End Configurations: Female BSP thread-Female BSP thread.
- Configuration: Body designs shall be straight through or 90 degree.
- Dual check valve shall be removable and replaceable with the valve fitted in place and in the closed position.

Brand Name	Manufacturer	Supplier	Approval Expires
Ball Valve Dual Check Valve	Strongcast Pty Ltd	Strongcast Pty Ltd	9/04/2025

Approved Materials List

Network: Water Supply (pressure)
Product Type: Dual Check Device Backflow Preventer
Material: Copper Alloy

Approval Type: Products listed below approved for use as permitted by IDS and CSS

Performance Requirements

Manufacturing Standard: AS/NZS 2845.1
Material Specification: Body: AS 1565 Copper Alloy, Dezincification Resistant (DZR) to AS 2345.
Valve Insert: Polyoxmethelene Acetyl. Seals: EPDM or Nitrile Rubber.
Coating Specification: N/A
Pressure Ratings: PN16
Approved Sizes: 15mm and 20mm Nominal Bore
Operational Life: 50 years
Other Requirements:

- Product shall be certified to AS/NZS 4020 or DWI (UK).
- End configurations: Female BSP Free Nut - BSP male threaded
- All devices shall meet the minimum requirements of the Building Act G12

Brand Name	Manufacturer	Supplier	Approval Expires
Water Meter Dual Check Valve	Strongcast Pty Ltd	Strongcast Pty Ltd	17/07/2025

Approved Materials List

Network: Water Supply (pressure)
Product Type: Double Check Valve Backflow Preventer (> 50mm)
Material: Ductile Iron (DI) or 316 Stainless Steel

Approval Type: Products listed below approved for use as permitted by IDS and CSS

Performance Requirements

Manufacturing Standard: AS/NZS 2845.1
Material Specification: Body: Ductile Iron (DI) to AS/NZS 2280 or 316 Stainless Steel.
 Seals: EPDM or Nitrile Rubber.
Coating Specification: DI shall have a thermally bonded polymeric coating to AS/NZS 4158.
Pressure Ratings: PN16
Approved Sizes: 65NB, 80NB, 100NB, 150NB and 200NB.
Operational Life: 50 years.
Other Requirements:

- Product shall be certified to AS/NZS 4020 or DWI (UK).
- End configurations: Flange - Flange. Flanges shall be fully compliant with AS/NZS 4087 Figure B5.

Brand Name	Manufacturer	Supplier	Approval Expires
FebCo 850	Watts Regulator	MRC Global	1/02/2024
Wilkins 350 Series	Zurn Wilkins	MacDonald Industries Ltd	19/11/2024

Approved Materials List

Network: Water Supply (pressure)
Product Type: Double Check Valve Backflow Preventer ($\leq 50\text{mm}$)
Material: Copper Alloy or Stainless Steel

Approval Type: Products listed below approved for use as permitted by IDS and CSS

Performance Requirements

Manufacturing Standard: AS/NZS 2845.1
Material Specification: Body: AS 1565 Copper Alloy, Dezincification Resistant (DZR) to AS 2345 or 316 Stainless Steel. Seals: EPDM or Nitrile Rubber.
Coating Specification: N/A
Pressure Ratings: PN16
Approved Sizes: 15NB, 20NB, 25NB, 32NB, 40NB and 50NB.
Operational Life: 50 years.
Other Requirements:

- Product shall be certified to AS/NZS 4020 or DWI (UK).
- End configurations: BSP Thread - BSP Thread.

Brand Name	Manufacturer	Supplier	Approval Expires
Wilkins 350 Series	Zurn Wilkins	MacDonald Industries Ltd	19/11/2024
Wilkins 950 Series	Zurn Wilkins	MacDonald Industries Ltd	19/11/2024
FebCo 850L	Watts Regulator	MRC Global	1/02/2024

Approved Materials List

Network: Water Supply (pressure)
Product Type: Reduced Pressure Zone Backflow Preventer (> 50mm)
Material: Ductile Iron (DI) or 316 Stainless Steel

Approval Type: Products listed below approved for use as permitted by IDS and CSS

Performance Requirements

Manufacturing Standard: AS/NZS 2845.1

Material Specification: Body: Ductile Iron (DI) to AS/NZS 2280 or 316 Stainless Steel.
Seals: EPDM or Nitrile Rubber.

Coating Specification: DI shall have a thermally bonded polymeric coating to AS/NZS 4158.

Pressure Ratings: PN16

Approved Sizes: 65NB, 80NB, 100NB, 150NB and 200NB.

Operational Life: 50 years.

Other Requirements:

- Product shall be certified to AS/NZS 4020 or DWI (UK).
- End configurations: Flange - Flange. Flanges shall be fully compliant with AS/NZS 4087 Figure B5.

Brand Name	Manufacturer	Supplier	Approval Expires
FebCo 860	Watts Regulator	MRC Global	1/02/2024
Wilkins 375 Series	Zurn Wilkins	MacDonald Industries Ltd	19/11/2024

Approved Materials List

Network: Water Supply (pressure)
Product Type: Reduced Pressure Zone Backflow Preventer (≤ 50mm)
Material: Copper Alloy or Stainless Steel

Approval Type: Products listed below approved for use as permitted by IDS and CSS

Performance Requirements

Manufacturing Standard: AS/NZS 2845.1
Material Specification: Body: AS 1565 Copper Alloy, Dezincification Resistant (DZR) to AS 2345 or 316 Stainless Steel. Seals: EPDM or Nitrile Rubber.
Coating Specification: N/A
Pressure Ratings: PN16
Approved Sizes: 15NB, 20NB, 25NB, 32NB, 40NB and 50NB.
Operational Life: 50 years.
Other Requirements:

- Product shall be certified to AS/NZS 4020 or DWI (UK).
- End configurations: BSP Thread - BSP Thread.

Brand Name	Manufacturer	Supplier	Approval Expires
Wilkins 375 Series	Zurn Wilkins	MacDonald Industries Ltd	19/11/2024
FebCo 860L	Watts Regulator	MRC Global	1/02/2024

Approved Materials List

Network: Water Supply (pressure)
Product Type: Swing Check Valve (Non-Testable)
Material: Ductile Iron (DI)

Approval Type: Products listed below approved for use as permitted by IDS and CSS

Performance Requirements

Manufacturing Standard: AS 4794
Material Specification: Body: Ductile Iron to AS/NZS2280. Disc & Stem: 316 or duplex Stainless Steel. Seals: Elastomeric to AS 1646.
Coating Specification: Thermally bonded polymeric coating to AS/NZS 4158.
Pressure Ratings: PN16
Approved Sizes: 80, 100, 125, 150, 175, 200, 225, 250, 300, 375, 450 and 600 nominal bore.
Operational Life: 100 years
Other Requirements:

- Product shall be certified to AS/NZS 4020 or DWI (UK).
- End configuration: Flange-Flange OR lugged. Flanges: To meet full requirements of AS/NZS 4087 Figure B5.

Brand Name	Manufacturer	Supplier	Approval Expires
AVK 41/80-001	AVK Australia Pty Ltd.	Humes	14/02/2024
AVK 41/81-001	AVK Australia Pty Ltd.	Humes	14/02/2024
AVK 41/81-003	AVK Australia Pty Ltd.	Humes	14/02/2024
AVK 41/81-004	AVK Australia Pty Ltd.	Humes	14/02/2024
AVK 41/82-001	AVK Australia Pty Ltd.	Humes	14/02/2024
AVK 41/82-003	AVK Australia Pty Ltd.	Humes	14/02/2024
AVK 41/82-004	AVK Australia Pty Ltd.	Humes	14/02/2024
Ozkan Tilting Disc Check Valve	Ozkan Makina	Hygrade	24/10/2024

Approved Materials List

Network: Water Supply (pressure)
Product Type: Dual-Plate Wafer Check Valve
Material: Ductile Iron (DI)

Approval Type: Products listed below approved for use as permitted by IDS and CSS

Performance Requirements

Manufacturing Standard: BS 5153

Material Specification: Body: Ductile Iron (DI) to AS/NZS2280. Disc & Stem: 316 or Duplex Stainless Steel. Seals: Elastomeric to AS1646.

Coating Specification: Thermally bonded polymeric coating to AS/NZS4158

Pressure Ratings: PN16

Approved Sizes: 100, 125, 150, 175, 200, 225, 250, 300, 375, 450 and 600 nominal bore.

Operational Life: 100 years

Other Requirements:

- Product shall be certified to AS/NZS 4020 or DWI (UK).
- End configuration: Flange-Flange OR lugged. Flanges to meet full requirements of AS/NZS 4087 Figure B5.

Brand Name	Manufacturer	Supplier	Approval Expires

Section 3

Mechanical Couplers & Adaptors

Fitting Type	Page
Unrestrained Mechanical Coupler	26
Restrained Mechanical Coupler	27
Restrained Mechanical Coupler for PE Pipe	28
Dismantling Joint	29

Approved Materials List

Network: Water Supply (pressure)
Product Type: Unrestrained Coupler
Material: Ductile Iron (DI)

Approval Type: Products listed below approved for use as permitted by IDS and CSS

Performance Requirements

Manufacturing Standard: AS/NZS 4998 OR EN 14525

Material Specification: Body: Ductile Iron to AS1831. Seals: EPDM or Nitrile Rubber to AS1646.
 Bolts, nuts and washers as per approved materials listing.

Coating Specification: Thermally bonded polymeric to AS/NZS 4158

Pressure Ratings: PN16

Approved Sizes: 100NB, 150NB, 200NB, 300NB, 375NB, 450NB and 600NB.

Operational Life: 130 years

Other Requirements:

- Product shall be certified to AS/NZS 4020 or DWI (UK).
- End configuration: Mechanical - Mechanical OR Mechanical - Flange.
 Flanges to meet full requirements of AS/NZS 4087 Figure B5.
- Stainless bolts, where used, shall have an anti-galling coating.
- Nominal size, maximum angle of deflection, nominal pipe setting gap and tightening torque shall be marked on each item.
- Unrestrained jointing of AC, CLS, CI, DI, PVC and Steel pipes 100 mm and above. Not to be used on PE pipe.

Brand Name	Manufacturer	Supplier	Approval Expires
Super-Gib Series 601	AVK Australia Pty Ltd.	Humes	14/02/2024
Series 603	AVK Australia Pty Ltd.	Humes	14/02/2024
MultiJoint 3000+	Georg Fisher Waga NV	Hynds	27/05/2024
MultiJoint 3050+	Georg Fisher Waga NV	Hynds	27/05/2024
MaxiFit Coupling	Viking Johnson	Hynds	25/08/2023
MaxiFit Adaptor	Viking Johnson	Hynds	25/08/2023

Approved Materials List

Network: Water Supply (pressure)
Product Type: Restrained Coupler
Material: Ductile Iron (DI)

Approval Type: Products listed below approved for use as permitted by IDS and CSS

Performance Requirements

Manufacturing Standard: EN 14525

Material Specification: Body: Ductile Iron to AS1831. Seals: EPDM or Nitrile Rubber to AS1646. Bolts, nuts and washers as per approved materials listing.

Coating Specification: Thermally bonded polymeric to AS/NZS 4158

Pressure Ratings: PN16

Approved Sizes: 100NB, 150NB, 200NB, 300NB, 375NB, 450NB and 600NB.

Operational Life: 130 years

Other Requirements:

- Product shall be certified to AS/NZS 4020 or DWI (UK).
- End configuration: Mechanical - Mechanical OR Mechanical - Flange. Flanges to meet full requirements of AS/NZS 4087 Figure B5.
- Stainless bolts, where used, shall have an anti-galling coating.
- Nominal size, maximum angle of deflection, nominal pipe setting gap and tightening torque shall be marked on each item.
- Restrained jointing of AC, CLS, CI, DI, PVC and Steel pipes 100 mm and above. Not to be used on PE pipe.

Brand Name	Manufacturer	Supplier	Approval Expires
Super-Maxi Series 631	AVK Australia Pty Ltd.	Humes	14/02/2024
Super-MaxiSeries 633	AVK Australia Pty Ltd.	Humes	14/02/2024
MultiJoint 3007+	Georg Fisher Waga NV	Hynds	27/05/2024
MultiJoint 3057+	Georg Fisher Waga NV	Hynds	27/05/2024
Synoflex Coupler	E Hawle Armaturenwerke Gmb	Hynds	31/03/2024
Synoflex Adaptor	E Hawle Armaturenwerke Gmb	Hynds	31/03/2024

Approved Materials List

Network: Water Supply (pressure)
Product Type: Restrained Coupler for PE Pipe
Material: Ductile Iron (DI)

Approval Type: Products listed below approved for use during repairs only.

Performance Requirements

Manufacturing Standard: EN 14525

Material Specification: Body: Ductile Iron to AS1831. Seals: EPDM or Nitrile Rubber to AS1646.
 Bolts, nuts and washers as per approved materials listing.

Coating Specification: Thermally bonded polymeric coating to AS/NZS 4158

Pressure Ratings: PN16

Approved Sizes: 100, 150, 200, 300, 375, 450 and 600 nominal bores.

Operational Life: 100 years

Other Requirements:

- Product shall be certified to AS/NZS 4020 or DWI (UK).
- End configuration: Mechanical - Mechanical OR Mechanical - Flange.
 Flanges to meet full requirements of AS/NZS 4087 Figure B5.
- Stainless bolts, where used, shall have an anti-galling coating.
- Nominal size, maximum angle of deflection, nominal pipe setting gap and tightening torque shall be marked on each item.
- Shall be designed specifically for use on PE pipes.
- Stainless steel support liners shall be installed in pipes.

Brand Name	Manufacturer	Supplier	Approval Expires
Super-Maxi Series 621	AVK Australia Pty Ltd.	Humes	14/02/2024
Super-MaxiSeries 623	AVK Australia Pty Ltd.	Humes	14/02/2024
System 2000 Coupler	E Hawle Armaturenwerke GmbH	Hynds	31/03/2024
System 2000 Adaptor	E Hawle Armaturenwerke GmbH	Hynds	31/03/2024

Approved Materials List

Network: Water Supply (pressure)
Product Type: Dismantling Joint
Material: Ductile Iron (DI)

Approval Type: Products listed below approved for use as permitted by IDS and CSS

Performance Requirements

- Manufacturing Standard:** N/A
- Material Specification:** Body: Ductile Iron to AS1831. Seals: EPDM or Nitrile Rubber to AS1646.
Bolts, nuts and washers as per approved materials listing.
- Coating Specification:** Thermally bonded polymeric coating to AS/NZS 4158
- Pressure Ratings:** PN16
- Approved Sizes:** 100, 150, 200, 300, 375, 450 and 600 nominal bores.
- Operational Life:** 100 years
- Other Requirements:**
- Product shall be certified to AS/NZS 4020 or DWI (UK).
 - End configuration: Flange - Flange. Flanges to meet full requirements of AS/NZS 4087 Figure B5.

Brand Name	Manufacturer	Supplier	Approval Expires
AVK Series 265/50	AVK Australia Pty Ltd.	Humes	14/02/2024
Hiwa	Fowry Tech (Shandong) Co. Ltd	Asmuss	26/12/2024

Section 4

Ductile Iron Fittings

Fitting Type	Page
Ductile Iron Bend	31
Ductile Iron Tee	32
Ductile Iron Spool	33
Ductile Iron Hydrant Riser	34
Ductile Iron Reducer	35
Ductile Iron Adaptor	36
Ductile Iron Coupler	37
Ductile Iron Cross	38

Approved Materials List

Network: Water Supply (pressure)
Product Type: DI Bends
Material: Ductile Iron (DI)

Approval Type: Products listed below approved for use as permitted by IDS and CSS

Performance Requirements

Manufacturing Standard: AS/NZS 2280
Material Specification: Body: DI to AS/NZS 2280. Seals: EPDM or Nitrile Rubber.

Coating Specification: Thermally bonded polymeric coating to AS/NZS 4158.
Pressure Ratings: PN16
Approved Sizes: 100NB, 150NB, 200NB, 300NB, 375NB, 450NB, 600NB.
Operational Life: 130 Years
Other Requirements:

- Product shall be certified to AS/NZS 4020 or DWI (UK).
- End configurations: Flange-Flange, Socket-Socket or Flange-Socket.
- Flanges shall be fully compliant with AS/NZS 4087 Figure B5.
- Approved Deflections 11.25°, 22.5°, 45° and 90°.

Brand Name	Manufacturer	Supplier	Approval Expires
Asmuss	Asmuss	Asmuss	11/09/2023
AVK Series 718	AVK Australia Pty Ltd	Humes	14/02/2024
Tyton	AVK Australia Pty Ltd	Asmuss Water Systems Ltd	14/02/2024
Derwent DI Fittings	Derwent Industries Pty Ltd	Hynds, Derwent	4/07/2024
Gillies DI Fittings	Gillies Metaltech	Hynds	17/07/2023
DI Max	Himgiri Castings Pvt Ltd	Reece Group	3/09/2023
Mallet	Mallet Industries Pty Ltd	Kennilworth Plumbing	6/11/2023
NIBF	Northern Iron and Brass Foundry Pty Ltd.	Humes	2/06/2014
Ductile Iron Fittings	Dalian Reliable Industrial Co Ltd.	Daemco Australia Pty Ltd	27/03/2024

Approved Materials List

Network: Water Supply (pressure)
Product Type: DI Tees
Material: Ductile Iron (DI)

Approval Type: Products listed below approved for use as permitted by IDS and CSS

Performance Requirements

Manufacturing Standard: AS/NZS 2280
Material Specification: Body: DI to AS/NZS 2280. Seals: EPDM or Nitrile Rubber.

Coating Specification: Thermally bonded polymeric coating to AS/NZS 4158.
Pressure Ratings: PN16
Approved Sizes: 100NB, 150NB, 200NB, 300NB, 375NB, 450NB, 600NB.
Operational Life: 130 Years
Other Requirements:

- Product shall be certified to AS/NZS 4020 or DWI (UK).
- End configurations: Flange-Flange-Flange, Flange-Flange-Hydrant Flange, Socket-Socket-Socket, Socket-Socket-Flange or Socket-Socket-Hydrant Flange.
- Flanges shall be fully compliant with AS/NZS 4087 Figure B5.
- Hydrant Tees shall have an 80NB branch.
- Branch may be a smaller diameter than the mainway.

Brand Name	Manufacturer	Supplier	Approval Expires
Asmuss	Asmuss	Asmuss	11/09/2023
AVK Series 718	AVK Australia Pty Ltd	Humes	14/02/2024
Tyton	AVK Australia Pty Ltd	Asmuss Water Systems Ltd	14/02/2024
Derwent DI Fittings	Derwent Industries Pty Ltd	Hynds, Derwent	4/07/2024
Gillies DI Fittings	Gillies Metaltech	Hynds	17/07/2023
DI Max	Himgiri Castings Pvt Ltd	Reece Group	3/09/2023
Mallet	Mallet Industries Pty Ltd	Kennilworth Plumbing	6/11/2023
NIBF	Northern Iron and Brass Foundry Pty Ltd.	Humes	2/06/2014
Ductile Iron Fittings	Dalian Reliable Industrial Co Ltd.	Daemco Australia Pty Ltd	27/03/2024

Approved Materials List

Network: Water Supply (pressure)
Product Type: DI Spools
Material: Ductile Iron (DI)

Approval Type: Products listed below approved for use as permitted by IDS and CSS

Performance Requirements

Manufacturing Standard: AS/NZS 2280
Material Specification: Body: DI to AS/NZS 2280. Seals: EPDM or Nitrile Rubber.

Coating Specification: Thermally bonded polymeric coating to AS/NZS 4158.
Pressure Ratings: PN16
Approved Sizes: 100NB, 150NB, 200NB, 300NB, 375NB, 450NB, 600NB.
Operational Life: 130 Years
Other Requirements:

- Product shall be certified to AS/NZS 4020 or DWI (UK).
- End configurations: Flange-Flange.
- Flanges shall be fully compliant with AS/NZS 4087 Figure B5.
- Spools for control of in-line thrusts shall have a puddle flange centrally placed and have minimum critical length of 3x thickness of thrust block.

Brand Name	Manufacturer	Supplier	Approval Expires
Asmuss	Asmuss	Asmuss	11/09/2023
AVK Series 718	AVK Australia Pty Ltd	Humes	14/02/2024
Tyton	AVK Australia Pty Ltd	Asmuss Water Systems Ltd	14/02/2024
Derwent DI Fittings	Derwent Industries Pty Ltd	Hynds, Derwent	4/07/2024
Gillies DI Fittings	Gillies Metaltech	Hynds	17/07/2023
DI Max	Himgiri Castings Pvt Ltd	Reece Group	3/09/2023
Mallet	Mallet Industries Pty Ltd	Kennilworth Plumbing	6/11/2023
NIBF	Northern Iron and Brass Foundry Pty Ltd.	Humes	2/06/2014
Ductile Iron Fittings	Dalian Reliable Industrial Co Ltd.	Daemco Australia Pty Ltd	27/03/2024

Approved Materials List

Network: Water Supply (pressure)
Product Type: DI Hydrant Risers
Material: Ductile Iron (DI)

Approval Type: Products listed below approved for use as permitted by IDS and CSS

Performance Requirements

Manufacturing Standard: AS/NZS 2280
Material Specification: Body: DI to AS/NZS 2280.

Coating Specification: Thermally bonded polymeric coating to AS/NZS 4158.
Pressure Ratings: PN16
Approved Sizes: 80NB
Operational Life: 130 Years
Other Requirements:

- Product shall be certified to AS/NZS 4020 or DWI (UK).
- End configurations: Flange-Flange.
- Flanges shall be fully compliant with AS/NZS 4087 Figure B5.
- A 50mm BSP offtake cast into the riser body is optional.

Brand Name	Manufacturer	Supplier	Approval Expires
Asmuss	Asmuss	Asmuss	11/09/2023
AVK Series 718	AVK Australia Pty Ltd	Humes	14/02/2024
Tyton	AVK Australia Pty Ltd	Asmuss Water Systems Ltd	14/02/2024
Derwent DI Fittings	Derwent Industries Pty Ltd	Hynds, Derwent	4/07/2024
Gillies DI Fittings	Gillies Metaltech	Hynds	17/07/2023
DI Max	Himgiri Castings Pvt Ltd	Reece Group	3/09/2023
Mallet	Mallet Industries Pty Ltd	Kennilworth Plumbing	6/11/2023
NIBF	Northern Iron and Brass Foundry Pty Ltd.	Humes	2/06/2014
Ductile Iron Fittings	Dalian Reliable Industrial Co Ltd.	Daemco Australia Pty Ltd	27/03/2024

Approved Materials List

Network: Water Supply (pressure)
Product Type: DI Reducers
Material: Ductile Iron (DI)

Approval Type: Products listed below approved for use as permitted by IDS and CSS

Performance Requirements

Manufacturing Standard: AS/NZS 2280
Material Specification: Body: DI to AS/NZS 2280. Seals: EPDM or Nitrile Rubber.

Coating Specification: Thermally bonded polymeric coating to AS/NZS 4158.

Pressure Ratings: PN16

Approved Sizes: 100NB, 150NB, 200NB, 300NB, 375NB, 450NB, 600NB.

Operational Life: 130 Years

Other Requirements:

- Product shall be certified to AS/NZS 4020 or DWI (UK).
- End configurations: Flange-Flange.
- Flanges shall be fully compliant with AS/NZS 4087 Figure B5.

Brand Name	Manufacturer	Supplier	Approval Expires
Asmuss	Asmuss	Asmuss	11/09/2023
AVK Series 718	AVK Australia Pty Ltd	Humes	14/02/2024
Tyton	AVK Australia Pty Ltd	Asmuss Water Systems Ltd	14/02/2024
Derwent DI Fittings	Derwent Industries Pty Ltd	Hynds, Derwent	4/07/2024
Gillies DI Fittings	Gillies Metaltech	Hynds	17/07/2023
DI Max	Himgiri Castings Pvt Ltd	Reece Group	3/09/2023
Mallet	Mallet Industries Pty Ltd	Kennilworth Plumbing	6/11/2023
NIBF	Northern Iron and Brass Foundry Pty Ltd.	Humes	2/06/2014
Ductile Iron Fittings	Dalian Reliable Industrial Co Ltd.	Daemco Australia Pty Ltd	27/03/2024

Approved Materials List

Network: Water Supply (pressure)
Product Type: DI Adaptors
Material: Ductile Iron (DI)

Approval Type: Products listed below approved for use as permitted by IDS and CSS

Performance Requirements

Manufacturing Standard: AS/NZS 2280
Material Specification: Body: DI to AS/NZS 2280. Seals: EPDM or Nitrile Rubber.

Coating Specification: Thermally bonded polymeric coating to AS/NZS 4158.

Pressure Ratings: PN16

Approved Sizes: 100NB, 150NB, 200NB, 300NB, 375NB, 450NB, 600NB.

Operational Life: 130 Years

Other Requirements:

- Product shall be certified to AS/NZS 4020 or DWI (UK).
- End configurations: Flange-Socket or Flange-Spigot.
- Flanges shall be fully compliant with AS/NZS 4087 Figure B5.

Brand Name	Manufacturer	Supplier	Approval Expires
Asmuss	Asmuss	Asmuss	11/09/2023
AVK Series 718	AVK Australia Pty Ltd	Humes	14/02/2024
Tyton	AVK Australia Pty Ltd	Asmuss Water Systems Ltd	14/02/2024
Derwent DI Fittings	Derwent Industries Pty Ltd	Hynds, Derwent	4/07/2024
Gillies DI Fittings	Gillies Metaltech	Hynds	17/07/2023
DI Max	Himgiri Castings Pvt Ltd	Reece Group	3/09/2023
Mallet	Mallet Industries Pty Ltd	Kennilworth Plumbing	6/11/2023
NIBF	Northern Iron and Brass Foundry Pty Ltd.	Humes	2/06/2014
Ductile Iron Fittings	Dalian Reliable Industrial Co Ltd.	Daemco Australia Pty Ltd	27/03/2024

Approved Materials List

Network: Water Supply (pressure)
Product Type: DI Coupler
Material: Ductile Iron (DI)

Approval Type: Products listed below approved for use as permitted by IDS and CSS

Performance Requirements

Manufacturing Standard: AS/NZS 2280
Material Specification: Body: DI to AS/NZS 2280. Seals: EPDM or Nitrile Rubber.

Coating Specification: Thermally bonded polymeric coating to AS/NZS 4158.
Pressure Ratings: PN16
Approved Sizes: 100NB, 150NB, 200NB, 300NB, 375NB, 450NB, 600NB.
Operational Life: 130 Years
Other Requirements:

- Product shall be certified to AS/NZS 4020 or DWI (UK).
- End configurations: Socket-Socket.
- Flanges shall be fully compliant with AS/NZS 4087 Figure B5.
- A 50mm BSP offtake cast into the connector body is optional.

Brand Name	Manufacturer	Supplier	Approval Expires
Asmuss	Asmuss	Asmuss	11/09/2023
AVK Series 718	AVK Australia Pty Ltd	Humes	14/02/2024
Tyton	AVK Australia Pty Ltd	Asmuss Water Systems Ltd	14/02/2024
Derwent DI Fittings	Derwent Industries Pty Ltd	Hynds, Derwent	4/07/2024
Gillies DI Fittings	Gillies Metaltech	Hynds	17/07/2023
DI Max	Himgiri Castings Pvt Ltd	Reece Group	3/09/2023
Mallet	Mallet Industries Pty Ltd	Kennilworth Plumbing	6/11/2023
NIBF	Northern Iron and Brass Foundry Pty Ltd.	Humes	2/06/2014
Ductile Iron Fittings	Dalian Reliable Industrial Co Ltd.	Daemco Australia Pty Ltd	27/03/2024

Approved Materials List

Network: Water Supply (pressure)
Product Type: DI Crosses
Material: Ductile Iron (DI)

Approval Type: Products listed below approved for use as permitted by IDS and CSS

Performance Requirements

Manufacturing Standard: AS/NZS 2280
Material Specification: Body: DI to AS/NZS 2280. Seals: EPDM or Nitrile Rubber.

Coating Specification: Thermally bonded polymeric coating to AS/NZS 4158.
Pressure Ratings: PN16
Approved Sizes: 100NB, 150NB, 200NB, 300NB, 375NB, 450NB, 600NB.
Operational Life: 130 Years
Other Requirements:

- Product shall be certified to AS/NZS 4020 or DWI (UK).
- End configurations: Flange-Flange-Flange-Flange.
- Flanges shall be fully compliant with AS/NZS 4087 Figure B5.
- Branchs may be smaller diameters than the mainway.

Brand Name	Manufacturer	Supplier	Approval Expires
Asmuss	Asmuss	Asmuss	11/09/2023
AVK Series 718	AVK Australia Pty Ltd	Humes	14/02/2024
Tyton	AVK Australia Pty Ltd	Asmuss Water Systems Ltd	14/02/2024
Derwent DI Fittings	Derwent Industries Pty Ltd	Hynds, Derwent	4/07/2024
Gillies DI Fittings	Gillies Metaltech	Hynds	17/07/2023
DI Max	Himgiri Castings Pvt Ltd	Reece Group	3/09/2023
Mallet	Mallet Industries Pty Ltd	Kennilworth Plumbing	6/11/2023
NIBF	Northern Iron and Brass Foundry Pty Ltd.	Humes	2/06/2014
Ductile Iron Fittings	Dalian Reliable Industrial Co Ltd.	Daemco Australia Pty Ltd	27/03/2024

Section 5

Fusion Fittings

Fitting Type	Page
Electrofusion Bend	40
Electrofusion Tee	41
Electrofusion Coupler	42
Electrofusion Reducer	43
Stub Flange for Electrofusion Connection to Pipe	44
Electrofusion Transition Coupler - Male Thread	45
Electrofusion Transition Coupler - Female Thread	46

Approved Materials List

Network: Water Supply (pressure)
Product Type: Electrofusion Bends
Material: Polyethylene (PE)

Approval Type: Products listed below approved for use as permitted by IDS and CSS

Performance Requirements

Manufacturing Standard: AS/NZS 4129
Material Specification: Polyethylene (PE100) to AS/NZS 4131.

Coating Specification: N/A
Pressure Ratings: PN16
Approved Sizes: DN20, DN25, DN32, DN40, DN50, DN63, DN125 and DN180.
Operational Life: 100 years
Other Requirements:

- Product shall be certified to AS/NZS 4020 or DWI (UK).
- Approved deflections: 11.25, 22.5, 45 and 90 degrees.
- End Configurations: Electrofusion socket - Electrofusion socket.
- Refer to Appendix 1 - PE Manufacturers Actions memo.

Brand Name	Manufacturer	Supplier	Approval Expires
AGRU	Agru Kunststofftechnik Gmbh	Hynds	9/02/2017
Frialen	Friatec Aktiengesellschaft	Humes	31/08/2023
Fusamatic	Fusion Group Ltd	Hynds	5/11/2023
+GF+	Georg Fisher Piping Systems Ltd	Hynds	27/05/2024
Plasson	Plasson Ltd, Israel	Humes, Hynds	3/02/2024
Plastitalia	Plastitalia Spa	Water Supply Products Ltd	2/11/2023
SABfuse	SAB Spa	P & I	2/11/2016

Approved Materials List

Network: Water Supply (pressure)
Product Type: Electrofusion Tees
Material: Polyethylene (PE)

Approval Type: Products listed below approved for use as permitted by IDS and CSS

Performance Requirements

Manufacturing Standard: AS/NZS 4129
Material Specification: Polyethylene (PE100) to AS/NZS 4131.

Coating Specification: N/A
Pressure Ratings: PN16
Approved Sizes: DN20, DN25, DN32, DN40, DN50 and DN63
Operational Life: 100 years
Other Requirements:

- Product shall be certified to AS/NZS 4020 or DWI (UK).
- End configurations: EF socket-EF socket-EF socket.
- Refer to Appendix 1 - PE Manufacturers Actions memo.

Brand Name	Manufacturer	Supplier	Approval Expires
AGRU	Agru Kunststofftechnik Gmbh	Hynds	9/02/2017
Frialen	Friatec Aktiengesellschaft	Humes	31/08/2023
Fusamatic	Fusion Group Ltd	Hynds	5/11/2023
+GF+	Georg Fisher Piping Systems Ltd	Hynds	27/05/2024
Plasson	Plasson Ltd, Israel	Humes, Hynds	3/02/2024
Plastitalia	Plastitalia Spa	Water Supply Products Ltd	2/11/2023
SABfuse	SAB Spa	P & I	2/11/2016

Approved Materials List

Network: Water Supply (pressure)
Product Type: Electrofusion Couplers
Material: Polyethylene (PE)

Approval Type: Products listed below approved for use as permitted by IDS and CSS

Performance Requirements

Manufacturing Standard: AS/NZS 4129
Material Specification: Polyethylene (PE100) to AS/NZS 4131.

Coating Specification: N/A
Pressure Ratings: PN16
Approved Sizes: DN25-DN710.
Operational Life: 100 years
Other Requirements:

- Product shall be certified to AS/NZS 4020 or DWI (UK).
- End configurations: Electrofusion socket-Electrofusion socket.
- DN400 and larger shall only be used where butt welding is not possible.
- Refer to Appendix 1 - PE Manufacturers Actions memo.

Brand Name	Manufacturer	Supplier	Approval Expires
AGRU	Agru Kunststofftechnik Gmbh	Hynds	9/02/2017
Frialen	Friatec Aktiengesellschaft	Humes	31/08/2023
Fusamatic	Fusion Group Ltd	Hynds	5/11/2023
+GF+	Georg Fisher Piping Systems Ltd	Hynds	27/05/2024
Plasson	Plasson Ltd, Israel	Humes, Hynds	3/02/2024
Plastitalia	Plastitalia Spa	Water Supply Products Ltd	2/11/2023
SABfuse	SAB Spa	P & I	2/11/2016

Approved Materials List

Network: Water Supply (pressure)
Product Type: Electrofusion Reducers
Material: Polyethylene (PE)

Approval Type: Products listed below approved for use as permitted by IDS and CSS

Performance Requirements

Manufacturing Standard: AS/NZS 4129
Material Specification: Polyethylene (PE100) to AS/NZS 4131.

Coating Specification: N/A
Pressure Ratings: PN16
Approved Sizes: DN20-DN250.
Operational Life: 100 years
Other Requirements:

- Product shall be certified to AS/NZS 4020 or DWI (UK).
- Total reduction shall not exceed two sizes.
- End configurations: Electrofusion socket-Electrofusion socket.
- Reducers shall be tapered with a max flare angle of 45 degrees and not stepped.
- Refer to Appendix 1 - PE Manufacturers Actions memo.

Brand Name	Manufacturer	Supplier	Approval Expires
AGRU	Agru Kunststofftechnik Gmbh	Hynds	9/02/2017
Frialen	Friatec Aktiengesellschaft	Humes	31/08/2023
Fusamatic	Fusion Group Ltd	Hynds	5/11/2023
+GF+	Georg Fisher Piping Systems Ltd	Hynds	27/05/2024
Plasson	Plasson Ltd, Israel	Humes, Hynds	3/02/2024
Plastitalia	Plastitalia Spa	Water Supply Products Ltd	2/11/2023
SABfuse	SAB Spa	P & I	2/11/2016

Approved Materials List

Network: Water Supply (pressure)
Product Type: Stub Flange for Electrofusion Connection to Pipe
Material: Polyethylene (PE)

Approval Type: Products listed below approved for use as permitted by IDS and CSS

Performance Requirements

Manufacturing Standard: AS/NZS 4129
Material Specification: Polyethylene (PE100) to AS/NZS 4131.

Coating Specification: N/A
Pressure Ratings: PN16
Approved Sizes: DN125, DN180, DN250, DN355, DN400, DN450, DN560 and DN710.
Operational Life: 100 years
Other Requirements:

- Product shall be certified to AS/NZS 4020 or DWI (UK).
- End configurations: Spigot (long)-Flange.
- Backing rings shall be installed on each stub flange.
- Refer to Appendix 1 - PE Manufacturers Actions memo.
- Refer to Appendix 3 - CCC Stub Flange and Backing Rings Table.

Brand Name	Manufacturer	Supplier	Approval Expires
AGRU	Agru Kunststofftechnik Gmbh	Hynds	9/02/2017
Frialen	Friatec Aktiengesellschaft	Humes	31/08/2023
Fusamatic	Fusion Group Ltd	Hynds	5/11/2023
+GF+	Georg Fisher Piping Systems Ltd	Hynds	27/05/2024
Plasson	Plasson Ltd, Israel	Humes, Hynds	3/02/2024
Plastitalia	Plastitalia Spa	Water Supply Products Ltd	2/11/2023
SABfuse	SAB Spa	P & I	2/11/2016
EnviroFab Long Spigot Stub Flange	Enviropipes Pty Ltd	Enviropipes Pty Ltd	21/02/2024
PE Slim Flange	Solo Plastics	Humes	16/12/2023

Approved Materials List

Network: Water Supply (pressure)
Product Type: Electrofusion Transition Fitting - Male Thread
Material: Polyethylene (PE)

Approval Type: Products listed below approved for use as permitted by IDS and CSS

Performance Requirements

Manufacturing Standard: AS/NZS 4129
Material Specification: Body: Polyethylene (PE100) to AS/NZS 4131. Threaded section: Dezincification Resistant (DZR) Copper Alloy to AS 2345.
Coating Specification: N/A
Pressure Ratings: PN16
Approved Sizes: DN20/15NB, DN25/20NB, DN32/25NB, DN50/40NB and DN63/50NB.
Operational Life: 100 years
Other Requirements:

- Product shall be certified to AS/NZS 4020 or DWI (UK).
- End configurations: electrofusion socket - metal thread (male) OR PE spigot - metal thread (male)
- Angles: 0° (straight), 45° or 90° long radius.
- Threaded section shall be metallic.
- Refer to Appendix 1 - PE Manufacturers Actions memo.

Brand Name	Manufacturer	Supplier	Approval Expires
AGRU	Agru Kunststofftechnik Gmbh	Hynds	9/02/2017
Frialen	Friatec Aktiengesellschaft	Humes	31/08/2023
Fusamatic	Fusion Group Ltd	Hynds	5/11/2023
+GF+	Georg Fisher Piping Systems Ltd	Hynds	27/05/2024
Plasson	Plasson Ltd, Israel	Humes, Hynds	3/02/2024
Plastitalia	Plastitalia Spa	Water Supply Products Ltd	2/11/2023
SABfuse	SAB Spa	P & I	2/11/2016
MacPlast	MacPlast SRL	Humes, Hynds	13/12/2024

Approved Materials List

Network: Water Supply (pressure)
Product Type: Electrofusion Transition Fitting - Female Thread
Material: Polyethylene (PE)

Approval Type: Products listed below approved for use as permitted by IDS and CSS

Performance Requirements

Manufacturing Standard: AS/NZS 4129
Material Specification: Body: Polyethylene (PE100) to AS/NZS 4131. Threaded section: Dezincification Resistant (DZR) Copper Alloy to AS 2345.
Coating Specification: N/A
Pressure Ratings: PN16
Approved Sizes: DN20/15NB, DN25/20NB, DN32/25NB, DN50/40NB and DN63/50NB.
Operational Life: 100 years
Other Requirements:

- Product shall be certified to AS/NZS 4020 or DWI (UK).
- End configurations: electrofusion socket - metal thread (female) OR PE spigot - metal thread (female)
- Angles: 0° (straight), 45° or 90° long radius.
- Threaded section shall be metallic or a metallic insert.
- Refer to Appendix 1 - PE Manufacturers Actions memo.

Brand Name	Manufacturer	Supplier	Approval Expires
AGRU	Agru Kunststofftechnik Gmbh	Hynds	9/02/2017
Frialen	Friatec Aktiengesellschaft	Humes	31/08/2023
Fusamatic	Fusion Group Ltd	Hynds	5/11/2023
+GF+	Georg Fisher Piping Systems Ltd	Hynds	27/05/2024
Plasson	Plasson Ltd, Israel	Humes, Hynds	3/02/2024
Plastitalia	Plastitalia Spa	Water Supply Products Ltd	2/11/2023
SABfuse	SAB Spa	P & I	2/11/2016
MacPlast	MacPlast SRL	Humes, Hynds	13/12/2024
Long Spigot Stub Flange	Strata Precision Plastics	Humes, Hynds, Plumbing World	19/08/2023

Section 6

Butt-Weld Fusion Fittings

Fitting Type	Page
Butt-Weld Bend	48
Fabricated Bend	49
Butt-Weld Tee	50
Butt-Weld Reducer	51
Stub Flange for Butt-Fusion Connection to Pipe	52

Approved Materials List

Network: Water Supply (pressure)
Product Type: Butt-Weld Bends
Material: Polyethylene (PE)

Approval Type: Products listed below approved for use as permitted by IDS and CSS

Performance Requirements

Manufacturing Standard: AS/NZS 4129
Material Specification: Polyethylene (PE100) to AS/NZS 4131.

Coating Specification: N/A
Pressure Ratings: PN16 SDR11
Approved Sizes: 125, 160, 180, 200, 250, 315, 355, 400, 450, 560 and 710 OD.
Operational Life: 100 years
Other Requirements:

- Approved deflections: 11.25, 22.5, 45 and 90 degrees.
- End Configurations: Spigot - Spigot.
- Refer to Appendix 1 - PE Manufacturers Actions memo.

Brand Name	Manufacturer	Supplier	Approval Expires
Plastitalia	Plastitalia Spa	Water Supply Products Ltd	2/11/2023

Approved Materials List

Network: Water Supply (pressure)
Product Type: Fabricated Bend
Material: Polyethylene (PE)

Approval Type: Project specific approval required to use products listed below

Performance Requirements

Manufacturing Standard: AS/NZS 4129
Material Specification: PE100 to AS/NZS 4131

Coating Specification: N/A
Stiffness Ratings: PN16 following re-rating as per AS/NZS 4129
Approved Sizes: DN125 to DN710.
Operational Life: 100 years
Other Requirements:

- End configurations: spigot-spigot.
- Fabricated bends shall use AS/NZS4130 pipe that is either bent following heating or mitre cut and welded.
- Refer to Appendix 1 - PE Manufacturers Actions memo.

Brand Name	Manufacturer	Supplier	Approval Expires
EnviroFab Sweep Bends	Enviropipes Pty Ltd	Enviropipes Pty Ltd	21/02/2024
EnviroFab Segment Bends	Enviropipes Pty Ltd	Enviropipes Pty Ltd	21/02/2024
PN16 Segmented Bends	Strata Precision Plastics	Humes, Hynds, Plumbing World	19/08/2023

Approved Materials List

Network: Water Supply (pressure)
Product Type: Butt-Weld Tees
Material: Polyethylene (PE)

Approval Type: Products listed below approved for use as permitted by IDS and CSS

Performance Requirements

Manufacturing Standard: AS/NZS 4129
Material Specification: Polyethylene (PE100) to AS/NZS 4131.

Coating Specification: N/A
Pressure Ratings: PN16 SDR11
Approved Sizes: 125, 160, 180, 200, 250, 315, 355, 400, 450, 560 and 710 OD.
Operational Life: 100 years
Other Requirements:

- End configurations: Spigot-Spigot-Spigot.
- Refer to Appendix 1 - PE Manufacturers Actions memo.

Brand Name	Manufacturer	Supplier	Approval Expires
Plastitalia	Plastitalia Spa	Water Supply Products Ltd	2/11/2023

Approved Materials List

Network: Water Supply (pressure)
Product Type: Butt-Weld Reducers
Material: Polyethylene (PE)

Approval Type: Products listed below approved for use as permitted by IDS and CSS

Performance Requirements

Manufacturing Standard: AS/NZS 4129
Material Specification: Polyethylene (PE100) to AS/NZS 4131.

Coating Specification: N/A
Pressure Ratings: PN16 SDR11
Approved Sizes: 125, 160, 180, 200, 250, 315, 355, 400, 450, 560 and 710 OD.
Operational Life: 100 years
Other Requirements:

- Total reduction shall not exceed two sizes.
- End configurations: Spigot-Spigot.
- Reducers shall be tapered with a max flare angle of 45 degrees and not stepped.
- Refer to Appendix 1 - PE Manufacturers Actions memo.

Brand Name	Manufacturer	Supplier	Approval Expires
Plastitalia	Plastitalia Spa	Water Supply Products Ltd	2/11/2023

Approved Materials List

Network: Water Supply (pressure)
Product Type: Stub Flange for Butt-Fusion Connection to Pipe
Material: Polyethylene (PE)

Approval Type: Products listed below approved for use as permitted by IDS and CSS

Performance Requirements

Manufacturing Standard: AS/NZS 4129
Material Specification: Polyethylene (PE100) to AS/NZS 4131.

Coating Specification: N/A
Pressure Ratings: PN16 SDR11
Approved Sizes: 90, 100, 125, 160, 180, 200, 250, 315, 355, 400, 450, 560 and 710 OD.
Operational Life: 100 years
Other Requirements:

- End configurations: Spigot (short)-Flange.
- Backing rings shall be installed on each stub flange.
- Refer to Appendix 1 - PE Manufacturers Actions memo.
- Refer to Appendix 3 - CCC Stub Flange and Backing Rings Table.

Brand Name	Manufacturer	Supplier	Approval Expires
Short Spigot Stub Flange	Strata Precision Plastics	Humes, Hynds, Plumbing World	19/08/2023
PE Slim Flange	Strata Precision Plastics	Humes, Hynds, Plumbing World	19/08/2023
PE Buttweld Stub Flange	Solo Plastics	Humes	16/12/2023
Plastitalia	Plastitalia Spa	Water Supply Products Ltd	2/11/2023

Section 7

Compression Fittings

Fitting Type	Page
Compression Bend	54
Compression Tee	55
Compression Coupler	56
Compression Reducer	57
Compression End Cap	58
Compression Transition Coupler - Male Thread	59
Compression Transition Coupler - Female Thread	60
Repair Coupler	61

Approved Materials List

Network: Water Supply (pressure)
Product Type: Compression Bends
Material: PP/POM

Approval Type: Products listed below approved for use as permitted by IDS and CSS

Performance Requirements

Manufacturing Standard: AS/NZS 4129

Material Specification: Body: Polypropylene (PP) or Polyoxymethylene (POM)
 Seals: EPDM or Nitrile Rubber

Coating Specification: N/A

Pressure Ratings: PN16

Approved Sizes: DN20, DN25, DN32, DN50 and DN63.

Operational Life: 100 years

Other Requirements:

- Product shall be certified to AS/NZS 4020 or DWI (UK).
- End configurations: Mechanical socket-Mechanical socket.
- Approved deflections: 11.25, 22.5, 45 or 90 degrees.
- PP/POM support liner to be inserted in pipe before installing fitting.

Brand Name	Manufacturer	Supplier	Approval Expires
+GF+ iJoint	Georg Fisher Piping Systems Ltd	Hynds	27/05/2024
EasyFit MD	Hansen Products NZ Ltd	Hansen Products NZ Ltd	29/07/2023
Philmac	Philmac Pty Ltd	Marley	0/01/1900
Plasson	Plasson Ltd, Israel	Humes, Hynds	Expired
Hydroflow Blueseal	SAB Spa	Asmuss	2/11/2016
Supreme	SAB Spa	P & I	2/11/2016
Talbot	Talis-UK Ltd	Hynds	31/03/2020
Connecto Plus Ultra	Irritec SPA	Water Supply Products Ltd	8/04/2024
Epsilon Series Bend	Elysee Irrigation Ltd	Waterworks NZ	17/01/2025

Approved Materials List

Network: Water Supply (pressure)
Product Type: Compression Tees
Material: PP/POM

Approval Type: Products listed below approved for use as permitted by IDS and CSS

Performance Requirements

Manufacturing Standard: AS/NZS 4129

Material Specification: Body: Polypropylene (PP) or Polyoxymethylene (POM)
 Seals: EPDM or Nitrile Rubber

Coating Specification: N/A

Pressure Ratings: PN16

Approved Sizes: DN20, DN25, DN32, DN50 and DN63.

Operational Life: 100 years

Other Requirements:

- Product shall be certified to AS/NZS 4020 or DWI (UK).
- End configurations: Mechanical socket-Mechanical socket-Mechanical socket.
- Threaded branch tees are not permitted.
- PP/POM support liner to be inserted in pipe before installing fitting.

Brand Name	Manufacturer	Supplier	Approval Expires
+GF+ iJoint	Georg Fisher Piping Systems Ltd	Hynds	27/05/2024
EasyFit MD	Hansen Products NZ Ltd	Hansen Products NZ Ltd	29/07/2023
Philmac	Philmac Pty Ltd	Marley	13/10/2023
Plasson	Plasson Ltd, Israel	Humes, Hynds	3/02/2024
Hydroflow Blueseal	SAB Spa	Asmuss	2/11/2016
Supreme	SAB Spa	P & I	2/11/2016
Talbot	Talis-UK Ltd	Hynds	31/03/2020
Connecto Plus Ultra	Irritec SPA	Water Supply Products Ltd	8/04/2024
Epsilon Series Tee	Elysee Irrigation Ltd	Waterworks NZ	17/01/2025

Approved Materials List

Network: Water Supply (pressure)
Product Type: Compression Couplers
Material: PP/POM

Approval Type: Products listed below approved for use as permitted by IDS and CSS

Performance Requirements

Manufacturing Standard: AS/NZS 4129
Material Specification: Body: Polypropylene (PP) or Polyoxymethylene (POM)
 Seals: EPDM or Nitrile Rubber
Coating Specification: N/A
Pressure Ratings: PN16
Approved Sizes: DN20, DN25, DN32, DN50 and DN63.
Operational Life: 100 years
Other Requirements:

- Product shall be certified to AS/NZS 4020 or DWI (UK).
- End configurations: Mechanical socket-Mechanical socket.
- PP/POM support liner to be inserted in pipe before installing fitting.

Brand Name	Manufacturer	Supplier	Approval Expires
+GF+ iJoint	Georg Fisher Piping Systems Ltd	Hynds	27/05/2024
EasyFit MD	Hansen Products NZ Ltd	Hansen Products NZ Ltd	29/07/2023
Philmac	Philmac Pty Ltd	Marley	13/10/2023
Plasson	Plasson Ltd, Israel	Humes, Hynds	Expired
Hydroflow Blueseal	SAB Spa	Asmuss	2/11/2016
Supreme	SAB Spa	P & I	2/11/2016
Talbot	Talis-UK Ltd	Hynds	31/03/2020
Connecto Plus Ultra	Irritec SPA	Water Supply Products Ltd	8/04/2024
Epsilon Series Coupler	Elysee Irrigation Ltd	Waterworks NZ	17/01/2025
Epsilon Series Repair Coupler	Elysee Irrigation Ltd	Waterworks NZ	17/01/2025

Approved Materials List

Network: Water Supply (pressure)
Product Type: Compression Reducers
Material: PP/POM

Approval Type: Products listed below approved for use as permitted by IDS and CSS

Performance Requirements

Manufacturing Standard: AS/NZS 4129

Material Specification: Body: Polypropylene (PP) or Polyoxymethylene (POM)
 Seals: EPDM or Nitrile Rubber

Coating Specification: N/A

Pressure Ratings: PN16

Approved Sizes: DN20, DN25, DN32, DN50 and DN63.

Operational Life: 100 years

Other Requirements:

- Product shall be certified to AS/NZS 4020 or DWI (UK).
- End configurations: Mechanical socket-Mechanical socket.
- Total reduction shall not exceed two sizes.
- PP/POM support liner to be inserted in pipe before installing fitting.

Brand Name	Manufacturer	Supplier	Approval Expires
+GF+ iJoint	Georg Fisher Piping Systems Ltd	Hynds	27/05/2024
EasyFit MD	Hansen Products NZ Ltd	Hansen Products NZ Ltd	29/07/2023
Philmac	Philmac Pty Ltd	Marley	13/10/2023
Plasson	Plasson Ltd, Israel	Humes, Hynds	3/02/2024
Hydroflow Blueseal	SAB Spa	Asmuss	2/11/2016
Supreme	SAB Spa	P & I	2/11/2016
Talbot	Talis-UK Ltd	Hynds	31/03/2020
Connecto Plus Ultra	Irritec SPA	Water Supply Products Ltd	8/04/2024
Epsilon Series Reducer	Elysee Irrigation Ltd	Waterworks NZ	17/01/2025

Approved Materials List

Network: Water Supply (pressure)
Product Type: Compression End Caps
Material: PP/POM

Approval Type: Products listed below approved for use as permitted by IDS and CSS

Performance Requirements

Manufacturing Standard: AS/NZS 4129
Material Specification: Body: Polypropylene (PP) or Polyoxymethylene (POM)
 Seals: EPDM or Nitrile Rubber
Coating Specification: N/A
Pressure Ratings: PN16
Approved Sizes: DN20, DN25, DN32, DN50 and DN63.
Operational Life: 100 years
Other Requirements:

- Product shall be certified to AS/NZS 4020 or DWI (UK).
- End Configuration: Mechanical Socket
- PP/POM support liner to be inserted in pipe before installing fitting.

Brand Name	Manufacturer	Supplier	Approval Expires
+GF+ iJoint	Georg Fisher Piping Systems Ltd	Hynds	13/10/2026
EasyFit MD	Hansen Products NZ Ltd	Hansen Products NZ Ltd	29/07/2023
Philmac	Philmac Pty Ltd	Marley	13/06/2026
Plasson	Plasson Ltd, Israel	Humes, Hynds	19/01/2026
Hydroflow Blueseal	SAB Spa	Asmuss	19/10/2020
Supreme	SAB Spa	P & I	19/10/2020
Talbot	Talis-UK Ltd	Hynds	13/12/2024
Connecto Plus Ultra	Irritec SPA	Water Supply Products Ltd	1/11/2024
Epsilon Series End Cap	Elysee Irrigation Ltd	Waterworks NZ	14/09/2025

Approved Materials List

Network: Water Supply (pressure)
Product Type: Compression Transition Fitting - Male Thread
Material: PP/POM

Approval Type: Products listed below approved for use as permitted by IDS and CSS

Performance Requirements

- Manufacturing Standard:** AS/NZS 4129
Material Specification: Body: Polypropylene (PP) or Polyoxymethylene (POM). Thread: Dezincification Resistant (DZR) Copper Alloy to AS 2345.
Coating Specification: N/A
Pressure Ratings: PN16
Approved Sizes: DN20/15NB, DN25/20NB, DN32/25NB, DN50/40NB and DN63/50NB.
Operational Life: 100 years
Other Requirements:
- Product shall be certified to AS/NZS 4020 or DWI (UK).
 - End configurations: mechanical socket - metal thread (male)
 - Angles: 0° (straight), 45° or 90° long radius.
 - Threaded section shall be metallic.
 - PP/POM support liner to be inserted in pipe before installing fitting.

Brand Name	Manufacturer	Supplier	Approval Expires
Plasson	Plasson Ltd, Israel	Humes, Hynds	3/02/2024

Approved Materials List

Network: Water Supply (pressure)
Product Type: Compression Transition Fitting - Female Thread
Material: PP/POM

Approval Type: Products listed below approved for use as permitted by IDS and CSS

Performance Requirements

Manufacturing Standard: AS/NZS 4129
Material Specification: Body: Polypropylene (PP) or Polyoxymethylene (POM). Thread: Dezincification Resistant (DZR) Copper Alloy to AS 2345.
Coating Specification: N/A
Pressure Ratings: PN16
Approved Sizes: DN20/15NB, DN25/20NB, DN32/25NB, DN50/40NB and DN63/50NB.
Operational Life: 100 years
Other Requirements:

- Product shall be certified to AS/NZS 4020 or DWI (UK).
- End configurations: mechanical socket - metal thread (female)
- Angles: 0° (straight), 45° or 90° long radius.
- Threaded section shall be metallic.
- PP/POM support liner to be inserted in pipe before installing fitting.

Brand Name	Manufacturer	Supplier	Approval Expires
+GF+ iJoint	Georg Fisher Piping Systems Ltd	Hynds	27/05/2024
Plasson	Plasson Ltd, Israel	Humes, Hynds	3/02/2024
Hydroflow Blueseal	SAB Spa	Asmuss	2/11/2016

Approved Materials List

Network: Water Supply (pressure)
Product Type: Repair Couplers
Material: PP/POM

Approval Type: Products listed below approved for use as permitted by IDS and CSS

Performance Requirements

Manufacturing Standard: AS/NZS 4129

Material Specification: Body: Polypropylene (PP) or Polyoxymethylene (POM)
 Seals: EPDM or Nitrile Rubber

Coating Specification: N/A

Pressure Ratings: PN16

Approved Sizes: DN20, DN25, DN32, DN50 and DN63.

Operational Life: 100 years

Other Requirements:

- Product shall be certified to AS/NZS 4020 or DWI (UK).
- End configurations: Mechanical socket-Mechanical socket.
- PP/POM support liner to be inserted in pipe before installing fitting.
- For use repairing HDPE or galv submains and laterals or connecting new MDPE to HDPE or galv.

Brand Name	Manufacturer	Supplier	Approval Expires
EasyFit MDID	Hansen Products NZ Ltd	Hansen Products NZ Ltd	29/07/2023
Global Transition Coupling	Elysee Irrigation Ltd	Waterworks NZ	17/01/2025
Universal Adaptor	Elysee Irrigation Ltd	Waterworks NZ	17/01/2025

Section 8

Junctions and Take-Off Fittings

Fitting Type	Page
Gunmetal Tapping Band	63
GRP Tapping Band	64
DI Tapping Band	65
Electrofusion Tapping Saddle	66
Electrofusion Branch Saddle	67
Mechanical Tapping Saddle	68
Mechanical Branch Saddle	69
DI Tapping Band for PE Pipe	70

Approved Materials List

Network: Water Supply (pressure)
Product Type: Gunmetal Tapping Band
Material: Copper Alloy

Approval Type: Products listed below approved for use as permitted by IDS and CSS

Performance Requirements

Manufacturing Standard: AS/NZS 4793
Material Specification: Body: AS 1565 Copper Alloy, Dezincification Resistant (DZR) to AS 2345.
 Seals: EPDM or Nitrile Rubber.

Coating Specification: N/A

Pressure Ratings: PN16

Approved Sizes: 100NB, 150NB, 200NB, 300NB

Operational Life: 100 years

- Other Requirements:**
- Product shall be certified to AS/NZS 4020 or DWI (UK).
 - Approved Tappings: 15, 20, 25 and 50mm female BSP threads.
 - Tapping diameter shall not exceed 30% of main pipe diameter.
 - Tapping bands shall be fully encircling.
 - The upper and lower sections of the tapping band shall contact, or have some mechanism to positively prevent deflection of the pipe when fasteners fully tightened.
 - Tappings greater than 25 mm shall not be made through pipe wall with a tapping saddle.
 - Not acceptable for use on PE mains.

Brand Name	Manufacturer	Supplier	Approval Expires
PI	Ningbo Yong Xiang Copper Pipeline Co Ltd	P & I	13/03/2018

Approved Materials List

Network: Water Supply (pressure)
Product Type: GRP Tapping Band
Material: Glass Reinforced Plastic (GRP)

Approval Type: Products listed below approved for use as permitted by IDS and CSS

Performance Requirements

Manufacturing Standard: AS/NZS 4973
Material Specification: Body: Norryl Glass Reinforced Plastic (GRP). Seals: EPDM or Nitrile Rubber. Nuts & Bolts: As per approved materials listing.
Coating Specification: N/A
Pressure Ratings: PN16
Approved Sizes: 100NB, 150NB and 200NB
Operational Life: 100 years
Other Requirements:

- Product shall be certified to AS/NZS 4020 or DWI (UK).
- Approved Tappings: 15, 20, 25 and 50mm female BSP threads.
- Tapping diameter shall not exceed 30% of main pipe diameter.
- Tapping bands shall be fully encircling.
- The upper and lower sections of the tapping band shall contact, or have some mechanism to positively prevent deflection of the pipe when fasteners fully tightened.
- Tappings greater than 25 mm shall not be made through pipe wall with a tapping saddle.
- Not acceptable for use on PE mains.

Brand Name	Manufacturer	Supplier	Approval Expires
4N Series 1 (White)	Stockbrands Co Pty Ltd	Waterworks NZ	12/02/2024
4N Series 1 (White)	Stockbrands Co Pty Ltd	Daemco Australia Pty Ltd	12/02/2024
4N Series 2 (Blue)	Stockbrands Co Pty Ltd	Waterworks NZ	12/02/2024
4N Series 2 (Blue)	Stockbrands Co Pty Ltd	Daemco Australia Pty Ltd	12/02/2024

Approved Materials List

Network: Water Supply (pressure)
Product Type: DI Tapping Band
Material: Ductile Iron (DI)

Approval Type: Products listed below approved for use as permitted by IDS and CSS

Performance Requirements

Manufacturing Standard: AS/NZS 4973

Material Specification: Body: Ductile Iron to AS/NZS 2280. Seals: EPDM or Nitrile Rubber. Nuts & Bolts: As per approved materials listing.

Coating Specification: Thermally Bonded Polymeric to AS/NZS 4158

Pressure Ratings: PN16

Approved Sizes: 100NB, 150NB, 200NB and 300NB

Operational Life: 100 years

Other Requirements:

- Product shall be certified to AS/NZS 4020 or DWI (UK).
- Approved Tappings: 15, 20, 25 and 50mm female BSP threads.
- Tapping diameter shall not exceed 30% of main pipe diameter.
- Tapping bands shall be fully encircling.
- The upper and lower sections of the tapping band shall contact, or have some mechanism to positively prevent deflection of the pipe when fasteners fully tightened.
- Tappings greater than 25 mm shall not be made through pipe wall with a tapping saddle.
- Not acceptable for use on PE mains.

Brand Name	Manufacturer	Supplier	Approval Expires
Uniclamp	Derwent Industries Pty Ltd	Derwent Industries Pty Ltd	4/07/2024

Approved Materials List

Network: Water Supply (pressure)
Product Type: Electrofusion Tapping Saddle
Material: Polyethylene (PE100)

Approval Type: Products listed below approved for use as permitted by IDS and CSS

Performance Requirements

Manufacturing Standard: AS/NZS 4129
Material Specification: Polyethylene (PE100)

Coating Specification: N/A
Pressure Ratings: PN16
Approved Sizes: DN50, DN63, DN125, DN180 and DN250.
Operational Life: 100 years
Other Requirements:

- Product shall be certified to AS/NZS 4020 or DWI (UK).
- Approved Tapping Sizes for DN50 & DN63: DN20, DN25 and DN32.
- Approved Tapping Sizes for DN125 and above: DN20, DN25, DN32, DN50 and DN63.
- End configuration: PE electrofusion spigot.
- Tapping saddles shall be monoblock or composite design.
- Tapping saddle shall have integral pipe cutter and pipe shall not be tapped prior to fitting being welded and tested.
- Refer to Appendix 1 - PE Manufacturers Actions memo.

Brand Name	Manufacturer	Supplier	Approval Expires
AGRU	Agru Kunststofftechnik GmbH	Hynds	9/02/2017
Frialen	Friatec Aktiengesellschaft	Humes	31/08/2023
Fusamatic	Fusion Group Ltd	Hynds	5/11/2023
+GF+	Georg Fisher Piping Systems Ltd	Hynds	27/05/2024
Plasson	Plasson Ltd, Israel	Humes, Hynds	3/02/2024
Plastitalia	Plastitalia Spa	P & I	2/11/2023
SABfuse	SAB Spa	P & I	2/11/2016

Approved Materials List

Network: Water Supply (pressure)
Product Type: Electrofusion Branch Saddle
Material: Polyethylene

Approval Type: Products listed below approved for use as permitted by IDS and CSS

Performance Requirements

Manufacturing Standard: AS/NZS 4129
Material Specification: Polyethylene (PE100)

Coating Specification: N/A
Pressure Ratings: PN16
Approved Sizes: DN50, DN63, DN125, DN180 and DN250.
Operational Life: 100 years
Other Requirements:

- Product shall be certified to AS/NZS 4020 or DWI (UK).
- Approved Tapping Sizes for DN50 & DN63: DN20, DN25 and DN32.
- Approved Tapping Sizes for DN125 and above: DN20, DN25, DN32, DN50 and DN63.
- End configuration: PE electrofusion spigot.
- Branch saddles shall have no constriction less than the internal diameter of the connecting pipe.
- Drill branch saddle AFTER fitting is welded and tested.
- Refer to Appendix 1 - PE Manufacturers Actions memo.

Brand Name	Manufacturer	Supplier	Approval Expires
AGRU	Agru Kunststofftechnik Gmbh	Hynds	9/02/2017
Frialen	Friatec Aktiengesellschaft	Humes	31/08/2023
Fusamatic	Fusion Group Ltd	Hynds	5/11/2023
+GF+	Georg Fisher Piping Systems Ltd	Hynds	27/05/2024
Plasson	Plasson Ltd, Israel	Humes, Hynds	3/02/2024
Plastitalia	Plastitalia Spa	P & I	2/11/2023
SABfuse	SAB Spa	P & I	2/11/2016

Approved Materials List

Network: Water Supply (pressure)
Product Type: Mechanical Tapping Saddle
Material: Polypropylene (PP) or Polyoxymethylene (POM)

Approval Type: Products listed below approved for use as permitted by IDS and CSS

Performance Requirements

Manufacturing Standard: AS/NZS 4129
Material Specification: Body: Polypropylene (PP) or Glass Reinforced Plastic (GRP). Seals: EPDM or Nitrile Rubber. Nuts and Bolts: 316 Stainless Steel.
Coating Specification: N/A
Pressure Ratings: PN16
Approved Sizes: DN50 and DN63.
Operational Life: 100 years
Other Requirements:

- Product shall be certified to AS/NZS 4020 or DWI (UK).
- Approved Tapping Sizes: 15NB, 20NB and 25NB.
- End configuration: Spigot or female BSP thread.
- Female threads shall be reinforced with a 316 stainless steel collar.
- Saddles to be fully encircling with not less than two fasteners on each side of fitting.

Brand Name	Manufacturer	Supplier	Approval Expires
+GF+	Georg Fisher Piping Systems Ltd	Hynds	27/05/2024
FastFit	Hansen Products NZ Ltd	Hansen Products NZ Ltd	29/07/2023
Philmac	Philmac Pty Ltd	Marley	13/10/2023
Plasson	Plasson Ltd, Israel	Humes, Hynds	3/02/2024
Hydroflow Blueseal	SAB Spa	Asmuss	2/11/2016
Supreme	SAB Spa	P & I	2/11/2016
Talbot	Talis-UK Ltd	Hynds	31/03/2020

Approved Materials List

Network: Water Supply (pressure)
Product Type: Mechanical Branch Saddle
Material: PP or GRP

Approval Type: Products listed below approved for use as permitted by IDS and CSS

Performance Requirements

Manufacturing Standard: AS/NZS 4129

Material Specification: Body: Polypropylene (PP) or Glass Reinforced Plastic (GRP). Seals: EPDM or Nitrile Rubber. Nuts and Bolts: 316 Stainless Steel.

Coating Specification: N/A

Pressure Ratings: PN16

Approved Sizes: DN50 and DN63.

Operational Life: 100 years

Other Requirements:

- Product shall be certified to AS/NZS 4020 or DWI (UK).
- Approved Tapping Sizes: 15NB, 20NB and 25NB.
- End configuration: Spigot or female BSP thread.
- Female threads shall be reinforced with a 316 stainless steel collar.
- Saddles to be fully encircling with not less than two fasteners on each side of fitting.
- Branch saddles shall have no constriction less than the internal diameter of the connecting pipe.

Brand Name	Manufacturer	Supplier	Approval Expires
4N PE (Black)	Stockbrands Co Pty Ltd	Waterworks NZ	12/02/2024
4N PE (Black)	Stockbrands Co Pty Ltd	Daemco Australia Pty Ltd	12/02/2024

Approved Materials List

Network: Water Supply (pressure)
Product Type: DI Tapping Band for PE Pipe
Material: Ductile Iron

Approval Type: Products listed below approved for use as permitted by IDS and CSS

Performance Requirements

Manufacturing Standard: AS/NZS 4129
Material Specification: Body: Ductile Iron (DI) to AS/NZS 2280. Seals: EPDM or Nitrile rubber. Nuts & bolts to comply to approved materials listing.
Coating Specification: Thermally bonded polymeric to AS/NZS 4158
Pressure Ratings: PN16
Approved Sizes: DN125, DN180 and DN250.
Operational Life: 100 years
Other Requirements:

- Product shall be certified to AS/NZS 4020 or DWI (UK).
- End Configurations: Branch with BSP thread or flanged offtake.
- Flanges: Shall meet full requirements of AS/NZS 4087.
- Only for installation on existing pipes

Brand Name	Manufacturer	Supplier	Approval Expires
Haku	E Hawle Armaturenwerke GmbH	Hynds	3/10/2023

Section 9

Surface Boxes

Surface Box Type	Page
Sluice Valve Box and Cover	72
Gate Valve Box and Cover	73
Fire Hydrant Box and Cover	74
Water Meter Box and Cover - Non-Trafficable	75
Heavy Duty Water Meter Box and Cover	76
Water Meter Box and Cover - Trafficable	77

Approved Materials List

Network: Water Supply (pressure)
Product Type: Sluice Valve Box and Cover
Material: Ductile Iron (DI)

Approval Type: Products listed below approved for use as permitted by IDS and CSS

Performance Requirements

Manufacturing Standard: AS/NZS 3996 or BS 5834-2
Material Specification: Ductile Iron to AS/NZS 2280

Coating Specification: N/A
Load Ratings: AS3996 Class D or EN 124 Class C minimum.
Approved Sizes: N/A
Operational Life: 50 years
Other Requirements:

- 225mm x 225mm minimum clear opening.
- Traffic Loading: Minimum AS/NZS 3996 Class D or EN 124 Class C.
- V or SV shall be permanently marked on lid.
- Lid and cover design shall be secure under traffic loads.

Brand Name	Manufacturer	Supplier	Approval Expires
Warrior HB54-1	PAM Saint Gobain	Pipe and Infrastructure	29/11/2023
Warrior HB80-1 (For pavement > 100mm)	PAM Saint Gobain	Pipe and Infrastructure	29/11/2023
Slam Lock Valve Box	RockHan Technology Co.	Hynds/Hygrade	20/05/2024

Approved Materials List

Network: Water Supply (pressure)
Product Type: Gate Valve Box and Cover
Material: Aluminium frame with steel lid.

Approval Type: Products listed below approved for use as permitted by IDS and CSS

Performance Requirements

Manufacturing Standard: AS 3996
Material Specification: Frame: Aluminium
Lid: Steel
Coating Specification: Steel lid shall be painted. No coating required on frame.
Load Ratings: AS3996 Class D.
Approved Sizes: N/A
Operational Life: 50 years
Other Requirements:

- 150mm diameter minimum clear opening.
- Traffic Loading: AS 3996 Class D.
- Lid shall be hinged.

Brand Name	Manufacturer	Supplier	Approval Expires
CHAL163	Unknown	Pipe and Infrastructure	#N/A

Approved Materials List

Network: Water Supply (pressure)
Product Type: Fire Hydrant Box and Cover
Material: Ductile Iron (DI)

Approval Type: Products listed below approved for use as permitted by IDS and CSS

Performance Requirements

Manufacturing Standard: AS/NZS 3996 or BS 5834-2
Material Specification: Ductile Iron to AS/NZS 2280

Coating Specification: N/A
Load Ratings: AS3996 Class D.
Approved Sizes: N/A
Operational Life: 50 years
Other Requirements:

- 380mm x 230mm minimum clear opening.
- Traffic Loading: AS 3996 Class D.
- FH shall be permanently marked on lid.
- Lid and cover design shall be secure under traffic loads.

Brand Name	Manufacturer	Supplier	Approval Expires
Warrior HB36-1FH	PAM Saint Gobain	Pipe and Infrastructure	29/11/2023
Slam Lock Hydrant Box	RockHan Technology Co.	Hynds/Hygrade	20/05/2024

Approved Materials List

Network: Water Supply (pressure)
Product Type: Water Meter Box and Cover (Non-Trafficable)
Material: Polyethylene (PE)

Approval Type: Products listed below approved for use as permitted by IDS and CSS

Performance Requirements

Manufacturing Standard: AS/NZS 3996
Material Specification: Polyethylene (PE100)

Coating Specification: N/A
Load Ratings: AS3996 Class A.
Approved Sizes: N/A
Operational Life: 50 years
Other Requirements:

- Minimum internal box dimensions 340mm x 180mm.
- Hinged black ABS lid.
- “Water Meter Box” shall be marked permanently on lid.
- Lid shall include a steel bar or plate to permit electronic detection.

Brand Name	Manufacturer	Supplier	Approval Expires
Strongcast conventional taper meter box and lid	Strongcast Pty Ltd	Hynds, Promains, Plumbing World, WSP	17/07/2025

Approved Materials List

Network: Water Supply (pressure)
Product Type: Heavy Duty Water Meter Box and Cover
Material: Galvanised Steel Lid

Approval Type: Products listed below approved for use as permitted by IDS and CSS

Performance Requirements

Manufacturing Standard: AS 3996
Material Specification: Box: Aluminium. Lid: Steel.

Coating Specification: N/A
Load Ratings: AS3996 Class C.
Approved Sizes: N/A
Operational Life: 80 years
Other Requirements:

- Minimum internal box dimensions 340mm x 200mm.
- Load Class: AS 3996 Class C
- “Water Meter Box” shall be marked permanently on lid.

Brand Name	Manufacturer	Supplier	Approval Expires
High Traffic Collar and Lid	Strongcast Pty Ltd	Hynds, Promains, Plumbing World, WSP	17/07/2025

Approved Materials List

Network: Water Supply (pressure)
Product Type: Trafficable Water Meter Box and Cover
Material: Ductile Iron (DI)

Approval Type: Products listed below approved for use as permitted by IDS and CSS

Performance Requirements

Manufacturing Standard: AS 3996
Material Specification: Ductile Iron to AS/NZS 2280

Coating Specification: N/A
Load Ratings: AS3996 Class C.
Approved Sizes: N/A
Operational Life: 80 years
Other Requirements:

- Minimum internal box dimensions 380mm x 230mm.
- Load Class: AS 3996 Class C
- “Water Meter Box” shall be marked permanently on lid.

Brand Name	Manufacturer	Supplier	Approval Expires
Warrior HB36-1WM	PAM Saint Gobain	Pipe and Infrastructure	29/11/2023

Section 10

Miscellaneous

Valve Type	Page
Steel Backing Ring	79
Conversion Flange	80
Repair Clamp	81
Galvanised Nuts, Bolts and Washers	82
Stainless Nuts, Bolts and Washers	82
Flange Gasket	83

Approved Materials List

Network: Water Supply (pressure)
Product Type: Steel Backing Ring
Material: Carbon Steel

Approval Type: Products listed below approved for use as permitted by IDS and CSS

Performance Requirements

Manufacturing Standard: AS/NZS 4087
Material Specification: Carbon steel to AS/NZS 3678 Grade 250.

Coating Specification: Thermally Bonded Polymeric to AS/NZS 4158
Pressure Ratings: PN16
Approved Sizes: 100, 150, 250, 350, 400, 450, 600 and 700.
Operational Life: 100 years
Other Requirements:

- Minimum Thickness: As per AS/NZS 4087.
- Refer to Appendix 3 - CCC Stub Flange and Backing Rings Table.

Brand Name	Manufacturer	Supplier	Approval Expires

Approved Materials List

Network: Water Supply (pressure)
Product Type: Conversion Flange
Material: Carbon Steel

Approval Type: Products listed below approved for use as permitted by IDS and CSS

Performance Requirements

Manufacturing Standard: None applicable.
Material Specification: Carbon steel to AS/NZS 3678 Grade 250.

Coating Specification: Thermally Bonded Polymeric to AS/NZS 4158
Pressure Ratings: PN16
Approved Sizes: 250x200, 350x300, 400x300, 450x375, 550x450 and 700x600.
Operational Life: 100 years.
Other Requirements:

- Product shall be certified to AS/NZS 4020 or DWI (UK).
- Flange drilling shall be to AS/NZS 4087 Figure B7.
- Studs shall be sealed to flange.
- Studs shall be prevented from turning.
- Conversion flange shall be fabricated to CCC standard drawings in Appendix 3 - CCC Stub Flange and Backing Rings Table

Brand Name	Manufacturer	Supplier	Approval Expires

Approved Materials List

Network: Water Supply (pressure)
Product Type: Repair Clamp
Material: Ductile Iron (DI) or Stainless Steel

Approval Type: Products listed below approved for use during repairs only.

Performance Requirements

Manufacturing Standard: AS 4181

Material Specification: Body: 316 Stainless Steel or 450-10 Ductile Iron to AS/NZS 2280.
 Seal: EPDM or Nitrile Rubber.

Coating Specification: DI: Thermally Bonded Polymeric to AS/NZS 4158. Stainless: N/A.

Pressure Ratings: PN16

Approved Sizes: To fit pipes 50-300NB.

Operational Life: 100 years

Other Requirements:

- Product shall be certified to AS/NZS 4020 or DWI (UK).
- Stainless units shall have stainless bolts, nuts and washers.
- Offtake repair clamps shall have BSP threads for offtake diameters up to and including 50mm. Larger offtakes shall have flanges To AS/NZS 4087 Fig B5.
- For application to AC, CI, DI, Galv. and PVC pipes only. For repair of cracked or damaged pipes, shall not be used where pipe is broken or axial loads are present.

Brand Name	Manufacturer	Supplier	Approval Expires
Rapid	Cascade SA	Hynds	22/09/2023
Kawandah	Derwent Industries Pty Ltd	Derwent Industries Pty Ltd	16/05/2024
Kawandah - Tapped	Derwent Industries Pty Ltd	Derwent Industries Pty Ltd	16/05/2024

Approved Materials List

Network: Water Supply (pressure)
Product Type: Nuts, Bolts and Washers
Material: Carbon Steel

Approval Type: Any product meeting the performance requirements may be used.

Performance Requirements

Manufacturing Standard: AS 4291.1
Material Specification: Carbon Steel

Coating Specification: Hot Dip Galvanising to AS/NZS 4680.
Pressure Ratings: N/A
Approved Sizes: N/A
Operational Life: 100 years
Other Requirements:

- Tensile Class: 8.8
- Washers shall be installed under nut and bolt head (where the heads are not encapsulated). Washer Thickness: 3mm minimum, 5mm minimum for M24 or larger bolts.
- All exposed metal surfaces including bolt heads and nuts shall be wrapped using a four part system including primer, mastic, petrolatum impregnated tape and tape overwrap.
- Bolt torque shall be between 60-65% of proof stress.

Network: Water Supply (pressure)
Product Type: Nuts, Bolts and Washers
Material: Stainless Steel

Approval Type: Any product meeting the performance requirements may be used.

Performance Requirements

Manufacturing Standard: AS 4291.1
Material Specification: 316 or A4 Stainless Steel

Coating Specification: N/A
Pressure Ratings: N/A
Approved Sizes: N/A
Operational Life: 100 years
Other Requirements:

- Washers shall be installed under nut and bolt head (where the heads are not encapsulated). Washer Thickness: 3mm minimum, 5mm minimum for M24 or larger bolts.
- All exposed metal surfaces including bolt heads and nuts shall be wrapped using a four part system including primer, mastic, petrolatum impregnated tape and tape overwrap.
- Bolt torque shall be between 60-65% of proof stress.

Approved Materials List

Network: Water Supply (pressure)
Product Type: Flange Gasket
Material: EPDM or Nitrile Rubber

Approval Type: Any product meeting the performance requirements may be used.

Performance Requirements

Manufacturing Standard: WSA 109
Material Specification: Ethylene Propylene Diene Monomer (EPDM) or Nitrile Butadiene Rubber (NB)

Coating Specification: N/A
Pressure Ratings: N/A
Approved Sizes: 80NB, 100NB, 150NB, 200NB, 300NB, 375NB, 450NB and 600NB.
Operational Life: 100 years
Other Requirements:

- Product shall be certified to AS/NZS 4020 or DWI (UK).
- Elastomeric gaskets shall be 3 mm or greater thick.
- Elastomeric gaskets shall be reinforced

Appendix 1

PE Manufacturers Action Memo

Polyethylene Pipe and Fitting Manufacturer

Actions Memorandum

PE pipe and any approved striping shall only be manufactured from 100% virgin raw materials.

Quality Assurance records

The manufacturer shall provide quality assurance records, particularly Melt flow rate and Thermal stability testing results, to the Engineer with each batch of pipe and fittings.

The Melt flow rate (MFR) test shall be determined in accordance with ISO 1133. A batch is as defined in clause A3.2 of AS/NZS 4130. The results can be for the resin from which the pipe batch was manufactured.

The MFR of the black or coloured compound shall not deviate by more than 30% from the value nominated by the compound manufacturer in accordance with cl 4.1.2 AS/NZS 4131.

Thermal stability shall be confirmed by determining the oxidation induction time (OIT) of a test specimen taken from the inside surface of the PE pipe and tested in accordance with ISO 11357-6 using oxygen at a test temperature of 200 deg C.

The OIT shall be equal to or greater than 20 minutes in accordance with cl 10.3 AS/NZS 4130.

Pre-supply Compatibility testing

Prior to the delivery of pipes and fittings, the manufacturer or supplier shall have the following complying tests undertaken by an accredited laboratory with all test results being forwarded to the Engineer.

The tests will apply to each pipe batch (and batch of fittings as applicable) and include two butt fusion welds, two electrofusion joint welds, two electrofusion saddle joint welds and two stub flange butt weld joints, with results being identified by pipe batch number. Where the weld type is not required by the project, testing for that weld type is not required.

- Tensile tests shall be in accordance with ISO 13953
- Peel decohesion tests shall be in accordance with ISO 13954 for pipe diameters 90mm and larger.
- Crushing decohesion tests shall be in accordance with ISO 13955 for pipe diameters smaller than 90mm.
- Saddle decohesion test shall be in accordance with ISO 13956

Compatibility Statement, welding parameters and witness mark measurements for electrofusion couplers

The following information shall be supplied by the manufacturer or supplier to the Engineer prior to delivery of pipe and fittings.

- The manufacturer shall state which fittings and batches of fittings have been tested as compatible with their PE pipe with reference to pipe batch numbers. This testing can apply to more than one project if the two projects are supplied from the same batch.
- Welding parameters for butt fusion and electrofusion couplers which have been confirmed by testing as applicable and compatible for the pipe and fittings shall be supplied, along with the welding plant model details.
- Witness mark measurements for the supplied electrofusion couplers shall be supplied by the manufacturer.

Appendix 2

PVC Witness Mark Memo

PVC Witness Mark Memorandum

Background

During restoration of the water supply and waste water infrastructure following the September and February earthquakes it has become apparent that the design of the socket and spigot joints between pipes is critical to the pipe's seismic performance.

It has been observed that joints which allow a greater range of movement are better able to accommodate ground movements. Essentially socket dimensions control the amount of elongation or compression that can be accommodated within the joint.

AS/NZS 1254 PVC-U pipes and fittings for stormwater and surface water applications and AS/NZS 1260 PVC-U pipes and fittings for drain, waste and vent application specify the Effective Sealing Length to be equal to the insertion depth plus the clearance between the end of the spigot and the base of the socket. Clause 4.7 also states: "the witness mark shall be provided for the full circumference of the pipe at a distance from the pipe end equivalent to the insertion depth +0-5 mm". (..) NOTE: The insertion depth/witness mark location may vary from manufacturer to manufacturer depending in the socket/joint design".

Purpose of this Memorandum

The purpose of this memorandum is to specify minimum socket dimensions and to clarify for suppliers and contractors what is required by Christchurch City Council (Council) for minimum socket dimensions and witness marking on approved Polyvinylchloride (PVC) pipes.

Performance Required

Witness marks on PVC pipes are required under AS/NZS 1254 and AS/NZS 1260 and are an established construction technique for ensuring the correct depth of engagement of socketed pipes. The correct alignment and insertion of the spigot into the socket allows the pipe to expand and contract under test and operating pressures, and allows the pipe to elongate and contract due to changes in operating temperature. Adopting a suitable insertion depth and clearance (gap between end of spigot and base of socket) will allow the pipe to elongate and compress when ground movement occurs.

Council require that socket dimensions be standardised to provide the deepest insertion length and clearance that can reasonably be formed by all manufacturers.

Recommendation for Witness mark

After consultation with the industry Council has adopted socket dimensions that are 25 mm longer than the minimum Effective Sealing Length specified by AS/NZS 12540 and AS/NZS 1260 (see sketch below).

The **Witness Mark** shall be placed so that there is a clearance (to act as a compression gap) of 25 mm between the end of the spigot and base of the socket.

A **Reference Mark** shall be placed 25 mm from the witness mark so that when the pipe is pushed home in the socket the reference mark is visible and 25 mm from the end of the pipe socket. The reference mark may be a band of clearly legible colour 25 mm wide and bordering the witness mark.

PVC Pipe Sizes NB (mm)	Minimum Effective Sealing Length (mm)
150	55
225	75
300	85
375	95

The following sketch illustrates the requirements.

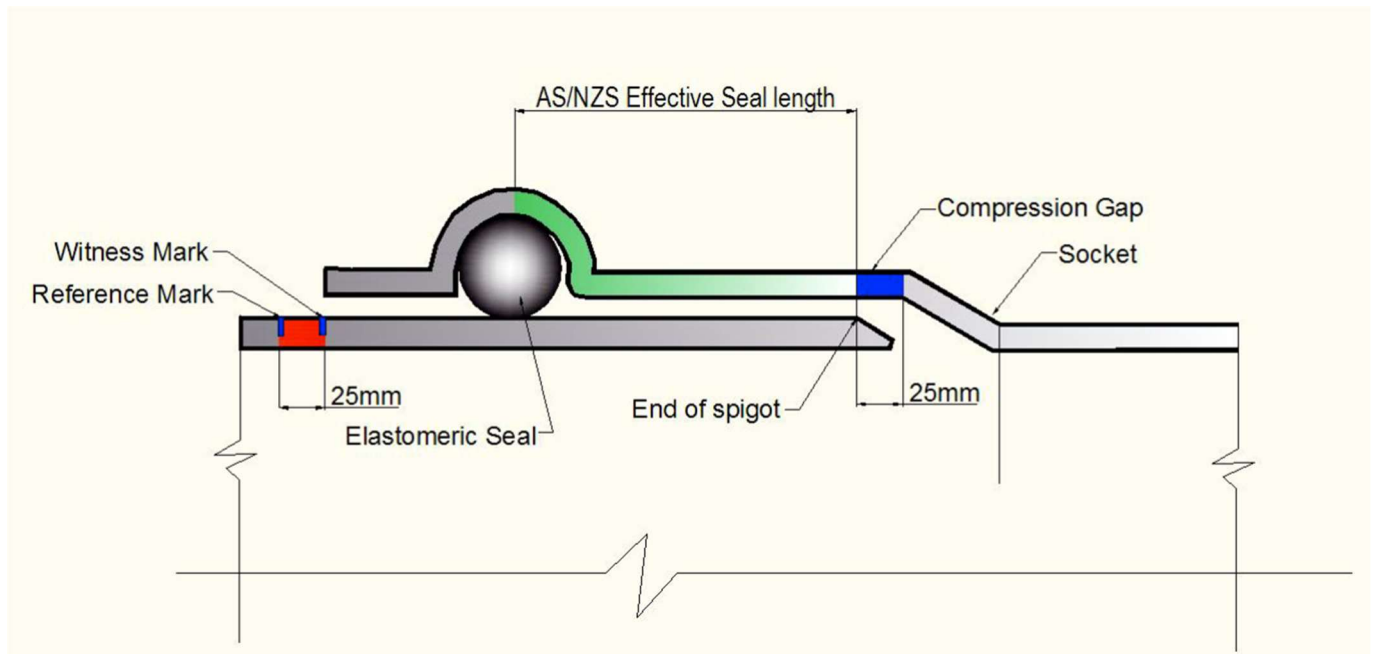

Additional information to assist pipe installers:

- Each witness mark must be placed around the circumference of the pipe barrel.
- All socketed/pipe connections must have a specific witness mark to match the correct socket depth.
- Each pipe spigot shall not be over-inserted or pushed beyond the witness mark (make sure the reference mark can be seen).
- Placing a witness mark around the circumference of the pipe barrel after pipe insertion is not permitted.

Appendix 3

Stub Flange and Backing Ring Table

Stub Flange and Backing Ring Tables

Conventional PE Stub Flange and Backing Ring

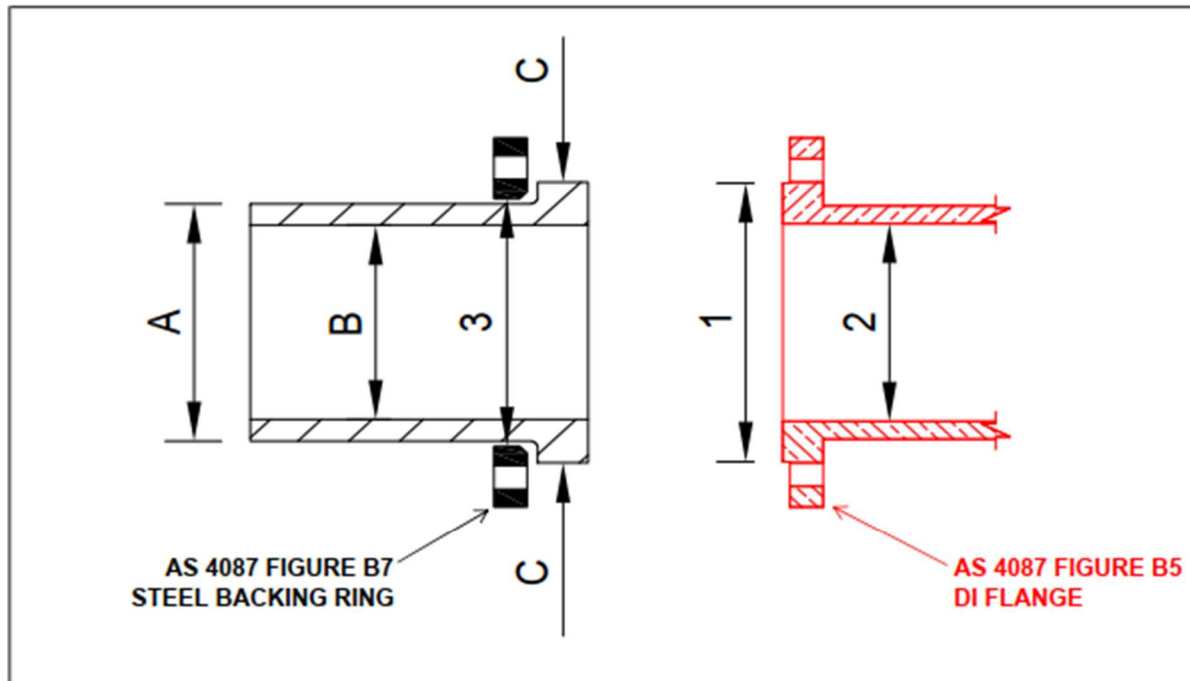

Nominal Bore	A (OD of PE)	SDR	B (ID of PE)	Back. Ring Flange Size* (see notes)	C (OD of PE Flange)	1 (OD of 4087 Raised Face)	% of Raised Face Engaged by PE Flange	2 (ID of Fitting)	Step in Bore	3 Backing Ring ID (from POP007)
100	125	13.6	108.6	100	164	154	99%	100	negligible	135
100	125	11.0	102.3	100	164	154	99%	100	negligible	135
150	180	13.6	153.5	150	220	211	99%	150	negligible	188
150	180	11.0	147.3	150	220	211	100%	150	negligible	188

* Note: Steel Backing Rings Shall Comply With AS 4087 Figure B7

Conventional PE Stub Flange and Backing Ring with Conversion Flange

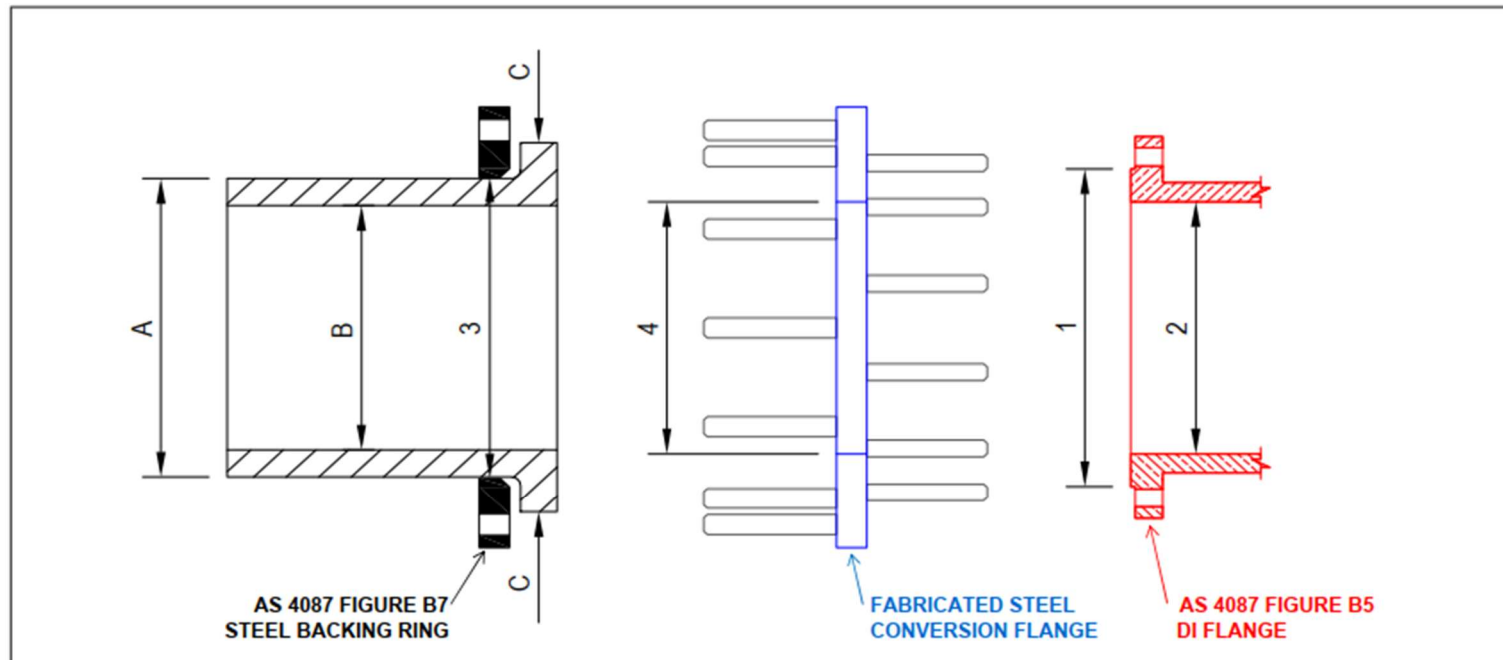

Nominal Bore	A (OD of PE Pipe)	SDR	B (ID of PE Pipe)	Back. Ring Flange Size* (from POP007) (see notes)	3 Back. Ring Flange ID (from POP007)	C (OD of PE Flange)	4 (ID of Conversion Flange)	Thickness of Conversion Flange	1 (OD of 4087 Raised Face)	% of Raised Face Engaged by PE Flange	Backing Ring ID (from POP007)	2 (ID of Fitting)	Step in Bore	Conversion Flange
100	125	13.6	106.6	100	135	164	N/A	N/A	154	99%	128	100	negligible	not required
100	125	11.0	102.3	100	135	164	N/A	N/A	154	99%	128	100	negligible	not required
150	180	13.6	153.5	150	188	220	N/A	N/A	211	99%	188	150	negligible	not required
150	180	11.0	147.3	150	188	220	N/A	N/A	211	100%	188	150	negligible	not required
200	250	13.6	213.2	250	288	332	200	30 mm	268	100%	288	200	approx. 12 mm	250 x 200
200	250	11.0	204.5	250	288	332	200	30 mm	268	100%	288	200	approx. 10 mm	250 x 200
300	355	13.6	302.8	350	376	442	300	30 mm	378	100%	376	300	negligible	350 x 300
300	355	11.0	290.5	350	376	442	300	30 mm	378	100%	376	300	approx. 10 mm	350 x 300
300	400	13.6	341.2	400	430	491	300	30 mm	378	100%	430	300	approx. 30 mm	
300	400	11.0	327.3	400	430	491	300	30 mm	378	100%	430	300	approx. 25 mm	
375	450	13.6	383.8	450	470	556	375	30 mm	463	100%	470	375	negligible	
375	450	11.0	368.2	450	470	556	375	30 mm	463	100%	470	375	negligible	

* Note: Steel Backing Rings Shall Comply With AS 4087 Figure B7

TYCO Pattern Slimline PE Stub Flange and Backing Ring

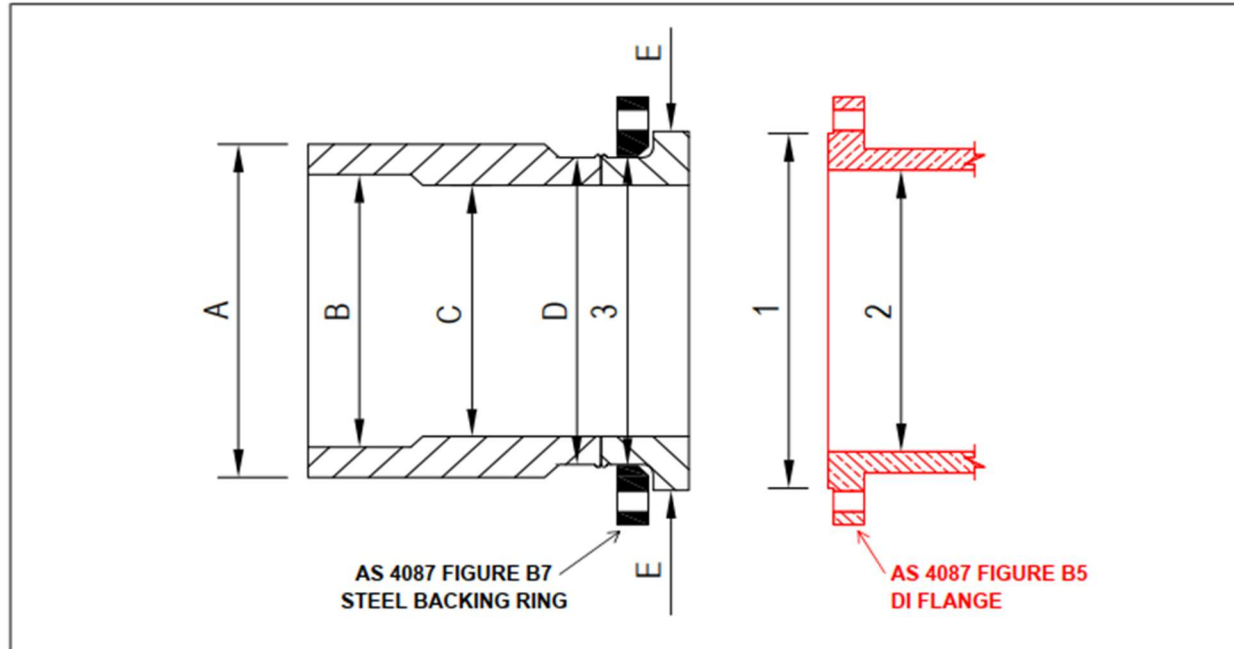

Nominal Bore	A (OD of PE Pipe)	SDR	B (ID of PE Pipe)	D (OD of Stub Flange - Flange End)	C (ID of Stub Flange - Flange End)	E (OD of PE Flange)	Back. Ring Flange Size* (see notes)	1 (OD of 4087 Raised Face)	% of Raised Face Engaged by PE Flange	3 Backing Ring ID (from Tyco)	2 (ID of Fitting)	Step in Bore	Conversion Flange
100	125	13.6	106.6	N/A	N/A	N/A	N/A	N/A	N/A	N/A	N/A	N/A	N/A
100	125	11.0	102.3	N/A	N/A	N/A	N/A	N/A	N/A	N/A	N/A	N/A	N/A
150	180	13.6	153.5	N/A	N/A	N/A	N/A	N/A	N/A	N/A	N/A	N/A	N/A
150	180	11.0	147.3	N/A	N/A	N/A	N/A	N/A	N/A	N/A	N/A	N/A	N/A
200	250	13.6	213.2	233.0	190.6	271.0	200	268	100%	237	200	approx. 10 mm	not required
300	355	13.6	302.8	327.0	267.5	382.0	300	378	100%	331	300	approx. 30 mm	not required
300	355	11.0	290.5	327.0	267.5	382.0	300	378	100%	331	300	approx. 30 mm	not required
300	400	13.6	341.2	327.0	267.5	382.0	300	378	100%	331	300	approx. 30 mm	not required
300	400	11.0	327.3	327.0	267.5	382.0	300	378	100%	331	300	approx. 30 mm	not required
375	450	13.6	383.8	439.0	359.0	465.0	375	463	100%	443	375	approx. 16 mm	not required
375	450	11.0	368.2	439.0	359.0	465.0	375	463	100%	443	375	approx. 16 mm	not required

Note: red text indicates size is estimated by GHD - not designed by Tyco

* Note: Steel Backing Rings shall Comply With AS 4087 Figure B7

PE to DI Conversion Flange

DN	OD - Flange		OD - Raised Face		PCD		Number of Bolts		Fastener		Hole Size	
	AS 4087	BS10 Table D	AS 4087	BS10 Table D	AS 4087	BS10 Table D	AS 4087	BS10 Table D	AS 4087	BS10 Table D	AS 4087	BS10 Table D
100	215	215	154	154	178	178	4	4	M16	M16	18	18
150	280	280	211	211	235	235	8	8	M16	M16	18	18
200	335	335	268	268	292	292	8	8	M16	M16	18	18
250 ¹	405	405	328	328	356	356	8	8	M20	M20	22	22
300	455	455	378	378	406	406	12	12	M20	M20	22	22
350 ²	525	525	438	438	470	470	12	12	M24	M24	26	26
375 ³	550	N/A	463	N/A	495	N/A	12	N/A	M24	N/A	26	N/A
400	580	580	489	489	521	521	12	12	M24	M24	26	26

- Notes:
- ¹ used with DN 250 stub flange
 - ² used with DN355 stub flange
 - ³ there is no DN375 in BS10 Table D

